

**INDYCAR**

*NTT INDYCAR SERIES*

**OFFICIAL  
RULE BOOK**



# TABLE OF CONTENTS

<b>1. GENERAL</b> .....	<b>5</b>
1.1. GOVERNANCE .....	5
1.2. ASSUMPTION OF RISK, LIABILITY RELEASE, ACKNOWLEDGMENT AND INDEMNITY .....	6
1.3. CONDUCT IDENTIFICATION.....	6
1.4. LITIGATION .....	6
1.5. SECURITY.....	6
1.6. DATA SHARING POLICY .....	7
<b>2. MEMBERSHIP</b> .....	<b>8</b>
2.1. GENERAL.....	8
2.2. APPLICATION.....	8
2.3. CATEGORIES.....	8
2.4. AGE .....	8
2.5. PHYSICAL AND PSYCHOLOGICAL FITNESS .....	8
2.6. MEDICAL EXAMINATIONS AND TREATMENT .....	9
2.7. DETERMINATION OF FITNESS.....	9
2.8. WAIVER OF CLAIMS.....	9
2.9. PENALTIES .....	9
2.10. VIOLATION OF LAWS .....	9
2.11. MEDICAL RECORDS .....	9
2.12. EVENT ACTIVITIES .....	9
2.13. MEMBERSHIPS, LICENSES AND CREDENTIALS.....	10
<b>3. SANCTIONS</b> .....	<b>11</b>
3.1. PROMOTION OF RACES.....	11
3.2. EVENT PROMOTER RESPONSIBILITIES .....	11
<b>4. ENTRANTS/DRIVERS</b> .....	<b>12</b>
4.1. GENERAL – ENTRANT LICENSING/DRIVER LICENSING.....	12
4.2. ENTRANT LICENSE .....	12
4.3. DRIVER.....	12
<b>5. ENTRIES</b> .....	<b>14</b>
5.1. GENERAL.....	14
5.2. ENTRANT.....	14
5.3. CAR .....	14
5.4. CHIEF MECHANIC.....	17
5.5. SPOTTERS.....	17
5.6. FEES.....	17
5.7. DEADLINE.....	18
5.8. ELECTRONIC ENTRIES .....	18
5.9. REOPENING OF ENTRIES .....	18
5.10. FAILURE TO PARTICIPATE .....	18
5.11. ENTRY CHANGE.....	18
<b>6. TESTING</b> .....	<b>19</b>
6.1. GENERAL.....	19
6.2. EFFECTIVE DATES .....	19
6.3. TESTING BLACKOUT PERIODS.....	19
6.4. APPLICATION AND REPORTING PROCESS .....	19
6.5. TEST PARTICIPANTS .....	19
6.6. APPROVED TESTING .....	20
6.7. TIRES.....	21
6.8. LOCATIONS.....	21
6.9. ADDITIONAL TESTING LIMITATIONS .....	22
6.10. VIOLATIONS.....	22

<b>7. AT TRACK PROCEDURES</b> .....	<b>23</b>
7.1. ON-TRACK CONDITIONS .....	23
7.2. FLAG CODES AND/OR TRACK CONDITION LIGHTS (COLLECTIVELY, “FLAGS”).....	25
7.3. TIMING AND SCORING .....	26
7.4. COMMUNICATION .....	27
7.5. PIT BOXES.....	28
7.6. RACE START .....	29
7.7. RACE RESTART.....	29
7.8. MECHANICAL CONDITIONS.....	30
7.9. PERFORMANCE STANDARDS .....	30
7.10. PIT PROCEDURES .....	30
7.11. PIT SAFETY VIOLATIONS.....	31
<b>8. QUALIFICATIONS</b> .....	<b>32</b>
8.1. ALL RACE LOCATIONS .....	32
8.2. OVAL EVENTS .....	33
8.3. ROAD/STREET COURSES .....	34
8.4. INDIANAPOLIS 500 <sup>®</sup> MILE RACE .....	36
<b>9. PENALTIES</b> .....	<b>37</b>
9.1. GENERAL.....	37
9.2. SCOPE OF PENALTIES.....	37
9.3. ADDITIONAL PROVISIONS AND GUIDELINES .....	38
<b>10. REVIEW</b> .....	<b>40</b>
10.1. INTRODUCTION.....	40
10.2. WHEN IS A REVIEW PERMITTED .....	40
10.3. WHO MAY REQUEST A REVIEW.....	40
10.4. PROCESS TO REQUEST A REVIEW .....	40
10.5. REVIEW PROCESS .....	41
10.6. COMPLIANCE WITH PROCEDURES.....	42
<b>11. APPEALS</b> .....	<b>43</b>
11.1. INTRODUCTION.....	43
11.2. WHEN IS AN APPEAL ALLOWED .....	43
11.3. WHO MAY REQUEST AN APPEAL .....	43
11.4. SUBMISSION OF APPEALS.....	43
11.5. APPEAL PROCESS AND HEARING.....	43
11.6. COMPLIANCE WITH PROCEDURES.....	45
<b>12. CHAMPIONSHIP AND POINTS</b> .....	<b>46</b>
12.1. CHAMPIONSHIPS AND POINT STANDINGS .....	46
12.2. SIGNIFICANCE OF THE CAR NUMBER .....	46
12.3. CREDITING OF POINTS.....	46
12.4. TIES.....	46
12.5. END OF SEASON AWARDS.....	46
12.6. POINTS .....	46
<b>13. COMMERCIAL ACTIVITIES &amp; AWARDS</b> .....	<b>49</b>
13.1. LOGO DISPLAY.....	49
13.2. ADVERTISING .....	49
13.3. TITLE SPONSOR.....	49
13.4. PRODUCT USE .....	49
13.5. MEDIA.....	50
13.6. AWARDS.....	51
<b>14. TECHNICAL SPECIFICATIONS</b> .....	<b>52</b>
14.1. GENERAL .....	52

14.2. DEVELOPMENT AREAS, REPRODUCTION PARTS, AND DIRECT PURCHASE PARTS .....	52
14.3. TECHNICAL INSPECTION .....	54
14.4. CAR WEIGHT AND DRIVER EQUIVALENCY WEIGHT .....	55
14.5. CHASSIS.....	55
14.6. DIMENSIONS.....	55
14.7. AERODYNAMICS.....	56
14.8. FUEL SYSTEM .....	65
14.9. STEERING AND SUSPENSION.....	65
14.10. DAMPERS AND INERTERS .....	66
14.11. DRIVESHAFTS / HUBS.....	66
14.12. ENERGY MANAGEMENT SYSTEM (EMS) .....	66
14.13. BRAKES.....	67
14.14. WHEELS.....	68
14.15. HEATING AND COOLING.....	68
14.16. GEARBOX/DIFFERENTIAL .....	69
14.17. AIRJACK .....	70
14.18. ELECTRONICS.....	70
14.19. DATA LOGGING AND TELEMETRY – CHASSIS AND ENGINE .....	72
14.20. FUEL .....	72
14.21. REFUELING .....	73
<b>15. TIRES .....</b>	<b>74</b>
15.1. GENERAL .....	74
15.2. TIRE ALLOTMENTS.....	74
15.3. ROAD COURSE/STREET COURSE TIRES.....	75
15.4. OVAL EVENTS.....	75
15.5. REPLACEMENT TIRES .....	75
<b>16. ENGINE SPORTING REGULATIONS .....</b>	<b>76</b>
16.1. INSTALLATION REQUIREMENTS .....	76
16.2. NUMBER OF ENGINES AND ENGINE MANAGEMENT .....	76
16.3. ENGINE MILEAGE.....	77
16.4. ENGINE CHANGE-OUT.....	77
16.5. APPROVED ENGINE CHANGE-OUTS.....	77
16.6. UNAPPROVED ENGINE CHANGE-OUTS .....	78
16.7. DOWN ON POWER ENGINES.....	79
16.8. ENGINE REPAIR .....	80
16.9. PARTIAL SEASON ENTRANTS .....	80
16.10. ENGINE INSPECTION.....	80
<b>17. EQUIPMENT &amp; GARAGES .....</b>	<b>81</b>
17.1. FUEL STORAGE TANKS.....	81
17.2. PIT LANE FIRE EQUIPMENT .....	82
17.3. EQUIPMENT.....	82
17.4. GARAGE.....	83
17.5. COVERS .....	83
<b>18. SAFETY.....</b>	<b>84</b>
18.1. SAFETY .....	84
<b>19. GLOSSARY.....</b>	<b>88</b>

**NTT INDYCAR SERIES  
RULE BOOK**

**PREFACE**

INDYCAR is the preeminent sanctioning body of open wheel racing in North America and functions with the purpose to promote the sport of automobile racing. As such, INDYCAR develops safety and competition regulations which are set forth in this book as it applies to the NTT IndyCar Series.

All INDYCAR Members, as well as every other person participating or involved in any way in the NTT IndyCar Series, shall be bound by these Rules, as amended, supplemented or superseded from time to time and shall be responsible for compliance. It is recommended that you read this Rule Book carefully to assure your familiarity with the rules and regulations contained herein.

Further information may be obtained by contacting the INDYCAR offices at 4551 West 16<sup>th</sup> Street, Indianapolis, IN 46222, Telephone (317) 492-6526, and [rules@indycar.com](mailto:rules@indycar.com).

# 1. GENERAL

## 1.1. Governance

### 1.1.1. General

- 1.1.1.1. The Rules govern the NTT IndyCar Series and supersede all previous Rules, bulletins and supplementary Rules and regulations, unless otherwise indicated. Capitalized terms used in the Rules have the meanings set forth in Rule 19, Glossary.
- 1.1.1.2. If the Rules do not expressly permit a variation, then the Member shall presume that such variation is not permitted. If a Member is uncertain if an act and/or part violates a Rule, the burden is on the Member to receive pre-approval in writing from INDYCAR. For this purpose, e-mails are not written approval unless otherwise expressly permitted and specified by INDYCAR by bulletin. The Member assumes the risk of noncompliance. It is not necessary for a competitive advantage to be gained to constitute a violation of these Rules.

### 1.1.2. INDYCAR Authority

- 1.1.2.1. The Rules shall be applied, constructed, and interpreted by INDYCAR, and INDYCAR's application, construction, and interpretation shall be final and binding.
- 1.1.2.2. INDYCAR reserves the right to create and/or revise the Rules at any time, including, without limitation, prior to or during an Event. Notices, bulletins, supplementary Rules, regulations, and penalties are effective on the date and time issued, regardless of the date and time when a Member receives actual notice.
- 1.1.2.3. INDYCAR shall have the right to enforce the Rules, including the rights to impose and/or remove penalties for any violation of the Rules. INDYCAR may penalize any Member and/or exclude any Member or equipment from any Event if INDYCAR deems any act, any omission, any condition to be hazardous and/or not meeting the specifications, requirements, spirit, illustrations, and/or intent of, the Rules.
- 1.1.2.4. INDYCAR shall have the right to determine whether or not to make public a notice stating that INDYCAR has penalized any Member and/or rendered a judgment on a review and/or appeal. If published, the notice may include without limitation a description of the penalty or judgment and names of the affected Member(s).
- 1.1.2.5. INDYCAR shall also have the following rights: (i) to authorize and supervise Events of any kind; (ii) to render decisions concerning the Rules and Events; (iii) to grant, approve, refuse, enforce or withdraw Licenses, memberships, and sanctions; (iv) to assign and cancel dates for Events; (v) to appoint and rescind the appointment of Officials; (vi) to establish, interpret and enforce standards of eligibility for participation in Events; and (vii) to do any and all things which, in its judgment, are consistent with the enhancement, safety and/or integrity of the Events. INDYCAR also reserves the right to take whatever action and/or impose whatever penalty it deems necessary to maintain the integrity and safety of INDYCAR, the NTT IndyCar Series, and/or its Events.

### 1.1.3. Officiating

- 1.1.3.1. INDYCAR will (i) secure necessary timing and scoring and technical equipment; (ii) and record all timing and scoring information and technical information, including the standings of an Event; (iii) control the designated timing and scoring and technical areas; (iv) provide competition information to the Competitors, the Event Promoter and the press; (v) and facilitate the award distributions. INDYCAR shall be the final authority on the content of all official postings. For clarity, all such information and data shall be the sole property of INDYCAR and all entities and individuals are strictly prohibited from using this information and data without express consent of INDYCAR.
- 1.1.3.2. INDYCAR may without limitation order the completion, postponement, or cancellation of any Event or any portion thereof for any reason. INDYCAR may terminate a Race before its scheduled number of laps or allotted time and in such case, determine the Race results and disposition of the awards and may terminate a Race after one or more Cars have finished. INDYCAR may increase or reduce the scheduled number of laps or allotted time, and/or may declare an Event completed, postponed, terminated or abandoned.
- 1.1.3.3. As soon as practical after the conclusion of an Event, INDYCAR shall prepare a report giving the results of the Event and may identify reviews lodged and any penalty issued.

### 1.1.4. Acceptance of the Rules

- 1.1.4.1. Every Member who is involved in and/or participates in any way in any Event shall be deemed to have a full awareness and understanding of and to have accepted, the Rules.
- 1.1.4.2. Every Member agrees to follow the direction of INDYCAR with respect to the enforcement and interpretation of these Rules or be subjected to penalties for failure to comply with such directions.
- 1.1.4.3. If an individual/entity is involved in and/or participates in any Event without having properly submitted fully-executed membership/licensing application materials, the individual/entity, by such involvement and/or participation, nevertheless agrees that the individual/entity is subject to all Rules, limitations of liability, indemnification and all statements, releases and obligations appearing in the membership/licensing application materials as if the individual/entity had properly submitted a fully-executed membership/licensing application materials and to the same extent as if such individual/entity were a Member.
- 1.1.4.4. The Rules shall be governed, interpreted and construed in accordance with the laws of the State of Indiana, without regard to its choice of law principles. All actions relating to the Rules shall be brought in state or federal court in Marion County, Indiana. Each Member consents to venue in and jurisdiction of the state or federal courts in Marion County, Indiana and waives any rights to contest such venue and jurisdiction.

## **1.2. Assumption of Risk, Liability Release, Acknowledgment and Indemnity**

**1.2.1. ASSUMPTION OF RISK - EVERY MEMBER AGREES TO BE BOUND BY THE RULES AND ASSUMES ALL OF THE RISK OF SUCH MEMBER'S INVOLVEMENT AND/OR PARTICIPATION IN AN EVENT.**

**1.2.2. LIABILITY RELEASE - RECOGNIZING THAT AUTOMOBILE RACING CAN BE A HAZARDOUS UNDERTAKING, MEMBERS, FOR THEMSELVES, THEIR HEIRS, EXECUTORS, REPRESENTATIVES, SUCCESSORS AND ASSIGNS, AGREE, BY THEIR MEMBERSHIP, THAT THEY RELEASE AND DISCHARGE INDYCAR GROUP FROM ANY AND ALL LIABILITY FOR DAMAGES TO PROPERTY, PERSONAL INJURY, AND/OR DEATH, IN ANY WAY RELATING TO ANY EVENT OR THE MEMBERS' INVOLVEMENT AND/OR PARTICIPATION IN THE EVENT, REGARDLESS OF HOW THE CLAIM MIGHT ARISE INCLUDING WITHOUT LIMITATION RACE OFFICIATING, RULE INTERPRETATION AND VIOLATIONS, PHYSICAL CONDITION OF THE TRACK, AND/OR EMERGENCY TREATMENT OR RESCUE.**

**1.2.3. ACKNOWLEDGMENT.**

**1.2.3.1. MEMBERS RECOGNIZE THIS RELEASE APPLIES EVEN IF INDYCAR GROUP OR ANY OF THE INDYCAR GROUP ACTED NEGLIGENTLY AND UNDERSTAND THAT MEMBERS MAY BE ASKED TO ACKNOWLEDGE THIS ASSUMPTION OF RISK AND RELEASE BY OTHER AGREEMENTS THEY MIGHT SIGN AS A PREREQUISITE TO PARTICIPATE IN AN EVENT OR EVENTS.**

**1.2.3.2. EACH MEMBER ACKNOWLEDGES THAT THE MEMBER HAS MADE THE MEMBER'S SPOUSE, DOMESTIC PARTNER, AND/OR DEPENDENTS AWARE OF THE MEMBER'S DECISION TO ASSUME AND INCUR THE RISK ASSOCIATED WITH RACING WITHOUT THE RIGHT TO PURSUE CLAIMS OF WRONGDOING.**

**1.2.4. INDEMNITY – EACH MEMBER ACKNOWLEDGES THAT MEMBER IS RESPONSIBLE FOR VIOLATION OF MEMBER'S AGREEMENTS BY MEMBER, MEMBER'S REPRESENTATIVES INCLUDING LOVED ONES AFFECTED BY MEMBER'S INVOLVEMENT AND/OR PARTICIPATION, AND MEMBER'S PARTICIPANTS AND GUESTS. THIS RESPONSIBILITY APPLIES TO ALL VIOLATIONS OF MEMBER'S AGREEMENTS WITH INDYCAR. THIS INCLUDES THE MISUSE OF CREDENTIALS AND THE FAILURE TO ACCEPT THE ASSUMPTION OF RISK, THE WAIVER AND RELEASE OF LIABILITY, THE BINDING NATURE OF THE RULES, INDYCAR'S INTERPRETATION OF THE RULES, AND THE FINALITY OF THE APPEAL PROCEDURE. MEMBER UNDERSTANDS THAT THIS RESPONSIBILITY INCLUDES THE DUTY TO INDEMNIFY AND HOLD INDYCAR GROUP HARMLESS FROM THE CONSEQUENCES AND DAMAGES ARISING FROM THE VIOLATION.**

**1.2.5. INDYCAR may periodically request that a Member acknowledge the release, assumption of risk and indemnification provisions in the membership application materials, but the failure of INDYCAR to request and/or a Member to sign an acknowledgement does not negate the release, assumption of risk and indemnification provisions in the membership application materials or in these Rules.**

## **1.3. Conduct Identification**

**1.3.1. A Member should never make a claim against INDYCAR or a person or entity connected with INDYCAR that an injury, including a fatal injury, has been caused by wrongful conduct that is intentional or willful and wanton unless the claim can be supported by established facts. Even if factually supportable, such a claim cannot continue unless the notice required in the membership application is timely completed.**

## **1.4. Litigation**

**1.4.1. Each Member agrees to reimburse INDYCAR Group and other named Members (INDYCAR Member Group) for all costs of litigation including without limitation travel expenses and attorneys' fees, costs and expenses if either of the following conditions occurs:**

**1.4.1.1. The Member initiates or otherwise causes a member of the INDYCAR Member Group to be named as a party in a legal proceeding not permitted or contemplated by the Rules;**

**1.4.1.2. The Member requests or compels a member(s) of the INDYCAR Member Group's participation in a manner other than as a party to the lawsuit.**

## **1.5. Security**

**1.5.1. Only authorized individuals are permitted on the Track and in other restricted locations designated by INDYCAR or an Event Promoter including without limitation spotter stands, marshal's posts, safety truck locations, photographer locations and broadcast platforms.**

**1.5.2. INDYCAR and the Event Promoter have the right to engage in such searches of individuals and property at any Event, as they deem necessary or appropriate for the safety and security of the Event. If they deem necessary, INDYCAR and the Event Promoter have the right but are not required to remove any individual and/or property from the Event.**

**1.5.3. INDYCAR may but is not required to penalize any Entrant, Associate, or other Member whose representative or equipment enters a restricted area at any Race Location prior to the scheduled opening time or remains in a restricted area at a Race Location after the scheduled closing time without prior approval from INDYCAR and the Event Promoter.**

**1.5.4. Only Members possessing a valid Driver's license may operate a motorized vehicle in a restricted area during an Event. Only INDYCAR-approved vehicles are permitted in the pit area. INDYCAR and/or an Event Promoter may have additional or different requirements for a particular Event.**

**1.5.5. Members must not operate or permit another individual to operate a motorized or non-motorized vehicle at the Race Location negligently, recklessly or without due consideration to Members, spectators or others.**

**1.5.6. Any Member involved in a crash or injured in an incident must report to the medical center or as directed by INDYCAR before departing the Race Location prior to the conclusion of the Event.**

**1.5.7. Smoking is not permitted on the Track, in the pit area, or in any fuel service area. INDYCAR and/or an Event Promoter may have additional or different requirements for a particular Event.**

**1.5.8. The possession of firearms by non-law enforcement personnel during an Event is prohibited.**

**1.5.9.** The use of drones or any other unmanned aircraft systems ("UAS") at an Event is prohibited unless approved in advance in writing by INDYCAR's President of Competition and Operations. As a condition of such approval, INDYCAR may require a Member to agree in writing with a policy statement that may include, without limitation: i) compliance with all applicable local, state and federal, rules and regulations; ii) adherence with INDYCAR-designated standards of use of the drone or UAS; iii) provision of insurance as required by INDYCAR and/or the Event promoter; and iv) completion of all applicable location releases and other agreements regarding the use of any photograph, video, footage, data, and/or other information gathered by the drone or UAS.

## **1.6. Data Sharing Policy**

**1.6.1.** INDYCAR owns any and all rights to exploit the NTT IndyCar Series and/or, without limiting the foregoing, the Events, or portions thereof, including without limitation, all photographic, video, audio, films, still and/or motion picture images, sounds and data or other reproductions thereof (e.g., in-car audio, in-car video, in-car radio, other electronic transmissions between cars and crews and timing and scoring information).

**1.6.2.** INDYCAR may disclose the data to third parties for any purpose including, without limitation, safety and/or medical research.

**1.6.3.** If an individual desires to receive any such data from INDYCAR, the individual shall submit a request in writing to the President of INDYCAR. The written request shall specify the date requested and the proposed use of the data.

**1.6.3.1.** INDYCAR shall determine whether to provide the data, taking into account such factors as the nature of the data requested, the uses for which the individual requests the data and whether or not consent and/or approval of any other individual is required or appropriate in order to release the data.

**1.6.3.2.** The individual requesting the data will be required to execute an agreement regarding approved uses for the data and the confidential treatment of any data that INDYCAR approves for use by the individual.

**1.6.4.** Notwithstanding the foregoing, an Entrant may record its own pit stop activities from its own pit area during Events for the purpose of internal evaluation. All other activities and/or uses require prior INDYCAR written approval.

**1.6.5.** INDYCAR owns any and all video footage captured via the AiM camera system. - Teams are required to retain all footage recorded by the AIM camera system for a minimum of 30 days.

**1.6.5.1.1.** Teams may utilize the footage obtained by the AiM camera system for internal evaluation purposes only and shall not use or distribute the footage in any other manner including- any commercial, promotional, or external usage via social media and other digital platforms.



## 2. MEMBERSHIP

### 2.1. General

INDYCAR is a voluntary membership organization. Each Member shall be deemed to be an independent contractor of INDYCAR and the relationship between INDYCAR and a Member shall not be deemed to be a partnership, joint venture, an employment or a franchise relationship by virtue of the membership. Members are responsible for the conduct of Member Group.

### 2.2. Application

2.2.1. Each applicant is required to submit the following properly executed materials for INDYCAR approval in the form required by INDYCAR:

- 2.2.1.1. Membership application,
- 2.2.1.2. Membership application fee,
- 2.2.1.3. Substance Abuse Policy Authorization for Testing and Release (if the applicant is a designated Competitor or Official),
- 2.2.1.4. Social Media Policy Acknowledgement (if the applicant is a Competitor or Official),
- 2.2.1.5. Participant Authorization for Use and Disclosure of Protected Health Information, and
- 2.2.1.6. Any other materials required by INDYCAR.

2.2.2. Membership criteria shall be determined by INDYCAR and may be periodically revised. Each applicant must be in Good Standing.

2.2.3. Applicants and Members agree INDYCAR may refuse a membership application or revoke a membership for any reason including, without limitation, those related to personal conduct, decency and whether or not any conduct of the applicant or Member creates adverse notoriety with respect to INDYCAR, the NTT IndyCar Series, or an Event.

2.2.4. Each applicant agrees to fulfill all contractual obligations such applicant and/or applicant's affiliates may have to INDYCAR, Event Promoters, Manufacturers and their affiliates. Each applicant agrees that INDYCAR, Event Promoters, Manufacturers and their affiliates shall have the remedy of specific performance with respect to any and all such obligations in addition to all other rights and remedies available at law or in equity and notwithstanding any terms to the contrary in any other agreement.

2.2.5. Each applicant must pay any and all outstanding financial obligations owed by applicant or its affiliates to INDYCAR, Manufacturers and their affiliates, or make other arrangements acceptable to INDYCAR, Manufacturers and their affiliates.

2.2.6. INDYCAR shall determine whether to accept or reject any membership application materials, although the rejection of membership application materials may be reviewed and/or appealed in accordance with the procedures set forth in [Rule 10](#) and [Rule 11](#).

2.2.7. Regardless of where the application material is executed by the applicant and/or accepted by INDYCAR and/or the credential issued, applicant recognizes and agrees that the Member's application materials and associated agreement is an Indiana contract and forms a contractual relationship established in the State of Indiana and governed by the laws of Indiana. This contract and relationship is a legal one and applicant should consult his/her attorney if he/she has any legal questions.

### 2.3. Categories

2.3.1. The following membership categories exist:

- a) Entrant
- b) Driver
- c) Associate
- d) Official
- e) Media
- f) VIP

### 2.4. Age

2.4.1. Unless otherwise specified, all applicants who are individuals must be at least eighteen (18) years of age. For example, INDYCAR may require a Competitor to be an age greater than eighteen (18) years of age or require additional and/or different requirements for a particular category and/or Event.

2.4.2. No one under age 18 shall be permitted in Pit Lane during any Events unless permitted by applicable insurance requirements and previously approved in writing by INDYCAR and/or the Event Promoter.

### 2.5. Physical and Psychological Fitness

2.5.1. INDYCAR may require any applicant or Member to complete a medical history form and/or complete and pass a medical examination which may include drug testing consistent with the provisions of the Substance Abuse Policy as directed by INDYCAR to determine physical and psychological fitness to receive a membership or License and/or to participate or continue in an Event. At any time, INDYCAR may require a Member to be examined and/or tested by a designated medical professional at the Member's cost.

2.5.2. Members must not use or be under the influence of illegal or prohibited drugs at any time, alcohol during an Event, and certain prescriptions and over-the-counter medications during an Event. Designated Competitors and Officials must complete and return to INDYCAR the current Substance Abuse Policy Authorization for Testing and Release and must comply with the provisions of the Substance Abuse Policy at all times. Whether or not an applicant or Member has formally executed the INDYCAR Substance Abuse Policy Authorization for Testing and Release, each applicant and Member agrees to submit to drug testing in accordance with the Substance Abuse Policy, which may include without limitation the collection of urine, blood, saliva, hair, breath and/or any other scientifically-acceptable method of analysis for prohibited substances and/or alcohol if requested by INDYCAR. Examination/testing may be for any drug, medication or other substance including without limitation alcohol. Applicants and Members shall be requested to regularly review the Substance Abuse Policy and will be notified by INDYCAR as changes to the Substance Abuse Policy are made. Changes to the Substance Abuse Policy will apply as they become effective

regardless of the actual notice and it is not an acceptable excuse for an applicant or Member to claim that the applicant or Member is unaware of a change to the Substance Abuse Policy or that such a change is not reflected in the Rules for purposes of avoiding the consequences of noncompliance.

**2.5.3.** Any applicant or Member who is required to complete a medical history form and/or complete and pass a medical examination/test shall also immediately notify in writing the INDYCAR Medical Director if the Member becomes aware of a change in the Member's medical condition, including if the Member is diagnosed with any medical condition (including pregnancy) by any medical professional.

**2.5.4.** Any Member who is required to execute the Substance Abuse Policy Authorization for Testing and release shall also submit proof of any prescription the Member is required to take to the INDYCAR Medical Review Officer (and receive the INDYCAR Medical Review Officer's approval of such use prior to taking the substance in connection with any Event) (whether or not prescription drugs or medication and regardless of how taken).

**2.5.5.** INDYCAR may disqualify, suspend or otherwise penalize any applicant or Member for failure to promptly cooperate with any request for examination/testing and/or notification by INDYCAR and for any pending violation of the Substance Abuse Policy.

## **2.6. Medical Examinations and Treatment**

**2.6.1.** Examinations and/or treatment of Members, including emergency rescue, performed by medical professionals acting on behalf of INDYCAR are based upon a relationship established in the State of Indiana.

**2.6.2.** Members acknowledge that the medical professionals engaged by INDYCAR are acting pursuant to their contractual obligations with INDYCAR and are not acting or rendering personal medical services to the Members. Members acknowledge that they shall have their own personal physicians.

## **2.7. Determination of Fitness**

Members acknowledge that while the INDYCAR medical professionals render an opinion as to fitness, the final determination of a Member's ability to participate is made by INDYCAR.

## **2.8. Waiver of Claims**

Each applicant and Member waives any and all claims regarding any medical treatment and/or medical examinations/testing and/or examination/testing results, and/or the use or disclosure of such medical treatment and/or medical examinations/testing and/or examination/testing results, by INDYCAR, its agents and/or its medical professionals including without limitation claims of invasion of privacy and/or breach of confidentiality, notwithstanding whether such claims arise from strict liability, sole or contributory negligence of INDYCAR, its agents and/or its medical professionals, breach of contract, or any other legal or equitable theory.

## **2.9. Penalties**

**2.9.1.** INDYCAR may disqualify, suspend or otherwise penalize any applicant or Member if the results of any examination/test are determined by INDYCAR, its agents and/or its medical professionals to be a violation of the INDYCAR Substance Abuse Policy or to enhance, impair, or otherwise affect the Member's ability to be involved in and/or participate in any Event regardless of whether the applicant or Member's B sample, if applicable, has confirmed the A sample finding, in the case of a drug test. INDYCAR in its discretion may suspend or otherwise penalize any applicant or Member while such applicant or Member's matter, whether it is a positive drug test or other violation of the Substance Abuse Policy or other applicable Rule, is pending or while INDYCAR investigates the applicant or Member's potential Rule violation.

**2.9.2.** Any Member who shows visible signs of exhaustion, physical or psychological impairment, or other physical or psychological irregularities may be disqualified and/or excluded from an Event and subjected to additional examinations/tests and/or penalties.

## **2.10. Violation of Laws**

Being charged with a violation of the law, whether alcohol/substance abuse or any other laws, may be grounds for suspension or other penalty. Any Member charged with any violation of the law relating to alcoholic beverages or illegal substances, or charged with any felony, must notify the President of Competition and Operations prior to the next scheduled Event or within 72 hours of being so charged, whichever is earlier, and cooperate with INDYCAR, including without limitation, providing additional information in order for INDYCAR to determine if a suspension or other penalty is appropriate.

## **2.11. Medical Records**

Each applicant and Member agrees and consents that, where requested by INDYCAR for purposes of carrying out its due diligence and obligations under the Rules and the Substance Abuse Policy, he or she will not unreasonably deny INDYCAR access to and copies of any and all medical records of the Member where access to such information may be necessary in order for INDYCAR to make a determination with respect to the applicant or Member's eligibility for participation in an Event. Applicants and Members acknowledge that denial of access by INDYCAR to such information may delay or prohibit INDYCAR from permitting the applicant or Member to compete and/or participate in Events.

## **2.12. Event Activities**

**2.12.1.** Activities - INDYCAR may schedule mandatory meetings and/or activities for Members. INDYCAR may require a meeting with Member(s) at any time. Each Member must attend and actively participate in all official meetings and other activities designated by INDYCAR as mandatory for that Member at the times and locations designated by INDYCAR. These may include, but are not limited to the following:

**2.12.1.1.1.** Competition Meetings - INDYCAR may conduct one or more meetings of Drivers, team managers, spotters and chief mechanics to discuss general application, construction and interpretation of the Rules and any specific Rules applying to a particular Event. INDYCAR has the right to determine attendees.

## **2.13. Memberships, Licenses and Credentials**

- 2.13.1.** Prior to gaining access to restricted areas, each individual must have the necessary and appropriate credential. The holder of a membership, License or other credential shall produce it for inspection upon demand of INDYCAR or security personnel at any Event along with any other document needed to confirm identification.
- 2.13.2.** The annual credential consists of both the lanyard and the hard card. Use of one without the other invalidates the annual credential. In addition, a Member must not use a prior Event's, prior racing season's or other series' credential.
- 2.13.3.** A membership, License or any other credential (including race mode) may not be disassembled, transferred, assigned, sold, made subject to a lien, altered, or duplicated. It must be used only by the Member to whom it is issued. If a Member intentionally or unintentionally disassembles, transfers, assigns, sells, makes subject to a lien, alters, duplicates or otherwise permits another individual or entity to use or attempt to use the membership, License or credential, then the Member may be penalized and shall indemnify and hold INDYCAR Group harmless from any loss or expense incurred by INDYCAR Group arising in any way from the Member's action, even if the Member or a third party asserts that INDYCAR Group's loss or expense is due to INDYCAR Group's negligence.
- 2.13.4.** The Rules regarding memberships, Licenses and credentials are equally applicable to parking passes, Event credentials, golf cart passes, and all other privileges issued to a Member by INDYCAR or an Event Promoter unless such credentials, passes or privileges are expressly transferable, assignable, or eligible for sale.
- 2.13.5.** INDYCAR may require an applicant and/or Member to provide a valid official government-issued identification including photograph and date of birth in order to receive or retain a credential. Acceptable identification includes without limitation a state driver's licenses, passports and military cards, but does not include identification issued by educational institutions or any nongovernmental entity.

## 3. SANCTIONS

### 3.1. Promotion of Races

INDYCAR will sanction Races with an Event Promoter through an Event Agreement. The Event Agreement contains additional terms regarding the Race, such as those relating to postponement dates.

### 3.2. Event Promoter Responsibilities

**3.2.1.** Event Promoters shall be responsible for designated operations including for example and without limitation responsibility for obtaining and providing, at the Event Promoter's expense, insurance as required by the Event Agreement, safety precautions, services and vehicles for Competitors and spectators including medical/rescue personnel, equipment, transportation and facilities (such as ambulances, air medical helicopters and examination facilities and equipment); physical condition of the Track; spectator control; and fire protection, all to meet or exceed the minimum requirements provided by INDYCAR and where applicable, the ASN.

**3.2.2.** INDYCAR shall not be responsible or in any manner liable for any of the Event Promoter's responsibilities under the Event Agreement or the Rules even if the Event Promoter fails or refuses to perform such functions, duties and responsibilities, in whole or in part, or if INDYCAR voluntarily assumes performance of any or all of the Event Promoter's specific functions, duties and responsibilities.

**3.2.3.** Members acknowledge that INDYCAR has the right to place additional regulations into effect if, in the discretion of INDYCAR and/or an Event Promoter, such additional regulations become desirable.

**3.2.4.** INDYCAR may require the Event Promoter to use, in compliance with local regulations and/or FIA requirements, medical/rescue personnel and equipment acceptable to INDYCAR to provide Members with assessment and treatment of emergency medical conditions.

## 4. ENTRANTS/DRIVERS

### 4.1. General – Entrant Licensing/Driver Licensing

- 4.1.1. Licensing criteria are available from the INDYCAR office and may vary depending on the particular on-Track activity. INDYCAR and ACCUS-FIA (and another ASN, if applicable) shall determine whether to approve a License application and issue a License. Applicant shall pay any and all costs associated with satisfying the License criteria. Driver Licenses are not transferable at any time; Entrant Licenses are not transferable without prior written approval.
- 4.1.2. Licenses are revocable by INDYCAR and ACCUS-FIA at any time and for any reason.
- 4.1.3. Eligibility for a License shall be determined based on such factors as are indicative of the applicant's ability to participate satisfactorily in an Event.
- 4.1.4. Fees may be charged for Licenses. Fees are non-refundable whether or not the License is granted. No fee or any part thereof shall be refunded to a licensee because the licensee ceases to participate in any Event(s) regardless of the reason for such cessation.
- 4.1.5. A License is valid only for the current Racing Season and/or as otherwise restricted. Licenses may be limited to a particular type of Event(s) or for a specified period. Licenses for Rookie Drivers are granted on a temporary basis. Unless otherwise noted, all Licenses shall expire on December 31st of the calendar year during which they were granted.
- 4.1.6. An applicant may request the review and/or appeal of a denial of a Driver or Entrant License and membership application, grade of Driver's License, determination of Rookie Driver status or eligibility for ROP or refresher Test in accordance with the procedures set forth in Rules 10 and 11.
- 4.1.7. INDYCAR may continuously re-evaluate the eligibility and performance of a Driver and/or Entrant to determine if the Driver and/or Entrant shall remain licensed. As part of such evaluation, INDYCAR may consider input from any Official, any Driver and others as INDYCAR determines appropriate and may require a Driver and/or Entrant to participate in Testing under the observation of Officials, Drivers, and/or others.

### 4.2. Entrant License

- 4.2.1. The individual signing the application materials represents that the individual is authorized to act on behalf of the named Entrant in all matters. Additional corporate representatives may be listed, and the authority of any individual may be limited.
  - 4.2.1.1. If a corporate representative's status changes, INDYCAR may require an individual authorized to act on behalf of the Entrant to submit new application materials for that Entrant for approval. INDYCAR may require an Entrant to submit another Entrant License fee and resubmit any other materials including, without limitation, a Leaders Circle Program Agreement, Entry forms, or any other requirements as determined by INDYCAR.
  - 4.2.1.2. Upon request, INDYCAR must be provided satisfactory information regarding ownership of an Entrant.
- 4.2.2. Eligibility
  - 4.2.2.1. Unless otherwise approved by INDYCAR, Entrant must possess an INDYCAR Entrant's License and Membership and an ACCUS-FIA Entrant's License (including international competition privileges). Entrant must remain in Good Standing at all times.
  - 4.2.2.2. After receipt of the application materials, the Entrant's competitive and business viability will be assessed to determine whether to approve and issue the license. Factors taken into account may include, without limitation:
    - 4.2.2.2.1. Purchase and/or lease agreements with Manufacturers;
    - 4.2.2.2.2. Purchase and/or lease agreement for its shop; and
    - 4.2.2.2.3. Employment or consultancy agreements with key personnel including, without limitation, team manager, engineer, chief mechanic and Driver.
- 4.2.3. Entry - Upon issuance of the Entrant License, the Entrant may submit a Leaders Circle Program Agreement and/or Entry forms identified by the Car number assigned to that Entrant License. The Entry (Car with Driver) must display the Car number at all times during the Event and all points and awards earned by this Entry will be credited to that Car number unless otherwise determined by INDYCAR. An Entrant intending to compete with multiple Entries at a single Event must obtain an Entrant License with a unique Car number for each Entry or satisfy such other requirements as INDYCAR may prescribe.
  - 4.2.3.1. The Entry shall automatically include a primary and Backup Car unless indicated otherwise. The first Car presented at technical inspection shall be the primary Car. The second Car presented at technical inspection shall be the Backup Car.
- 4.2.4. Manufacturers – The Manufacturers may require an Entrant to enter into lease and/or purchase agreements.

### 4.3. Driver

- 4.3.1. Each Entry form must list a Driver.
- 4.3.2. Driver License
  - 4.3.2.1. License application materials may be approved, and Licenses issued to individuals determined eligible by INDYCAR to compete in an Event and who otherwise meet the application requirements.
  - 4.3.2.2. INDYCAR and/or ACCUS-FIA (and another ASN, if applicable) shall determine the grade of the License issued to a Driver.

4.3.2.3. In order for a Driver to compete in any Event, the Driver must hold a Driver License and at any time may be required to:

- a) Participate in any INDYCAR required testing;
- b) Provide an updated resume, government-issued identification, and/or certified birth certificate;
- c) Furnish a current clearance acceptable to INDYCAR attesting to the Driver's physical/psychological fitness;
- d) Provide proof of United States residency and an international letter of authorization from the Driver's home country ASN, in the case of Drivers who are not citizens of the United States.

4.3.2.3.1. Eligibility

4.3.2.3.2. Unless otherwise approved by INDYCAR, Driver must possess an INDYCAR Driver's License and Membership and an ACCUS-FIA Driver's License (including international competition privileges) or another ASN Driver's License, if applicable. Driver must remain in Good Standing at all times.

4.3.2.3.3. Driver eligibility is at the sole discretion of INDYCAR.

4.3.2.3.4. INDYCAR may require the applicant to provide:

4.3.2.3.4.1. A current resume containing a complete history of the applicant's competition to date and demonstrating the applicant's ability to properly and safely handle the Car;

4.3.2.3.4.2. A letter of recommendation from the series in which the Driver last competed; and/or

4.3.2.3.4.3. Such other information as INDYCAR may request.

4.3.2.3.5. Physical/Psychological Information - The applicant must provide the information required by INDYCAR and must successfully complete any INDYCAR-prescribed physical and psychological examinations, which may include, without limitation, eye, neurological and substance abuse testing.

4.3.2.3.6. Refresher Tests - An applicant, including, without limitation, a Driver who has not participated as a Driver in any on-Track Event during the past six (6) months, may be required to successfully complete a refresher test. In lieu of a refresher test, INDYCAR may require an applicant to successfully complete ROP.

4.3.2.4. Rookie Driver General

4.3.2.4.1. Before a Rookie Driver's participation in his/her first (1<sup>st</sup>) Oval Event, the Rookie Driver must complete a ROP supervised by INDYCAR.

4.3.2.4.2. The determination of whether the applicant may take ROP and whether the applicant successfully completed ROP shall be made by INDYCAR.

4.3.2.4.3. If a Driver begins the Racing Season as a Rookie Driver, he/she remains a Rookie Driver until the end of that Racing Season.

4.3.2.4.4. ROP – An applicant must demonstrate Car control, placement and interaction with other Cars on-Track to the satisfaction of INDYCAR. INDYCAR may require additional testing including, without limitation, testing in close proximity to other Cars, before an applicant may be permitted to participate in an Open Test and/or Race.

4.3.2.5. Indianapolis 500<sup>®</sup> Mile Race Eligibility

4.3.2.5.1. A Driver is only eligible to be a Rookie Driver in the Indianapolis 500<sup>®</sup> Mile Race if the Driver has not participated in a prior Indianapolis 500<sup>®</sup> Mile Race.

4.3.2.5.2. ROP – Successful completion of ROP at another Race Location and/or participation in an on-Track Event does not may satisfy this requirement for the Indianapolis 500<sup>®</sup> Mile Race.

4.3.2.5.3. INDYCAR shall hold a mandatory Driver and team manager meeting prior to the beginning of the ROP session. At this meeting, INDYCAR will announce the speed phases and other requirements for the ROP.

4.3.2.5.4. In addition to Car control, placement and interaction with other Cars on-Track to the satisfaction of INDYCAR, the ROP shall consist of three phases, totaling 40 laps. The laps do not have to be consecutive.

4.3.2.5.5. Rookie Drivers must successfully complete a minimum of two of the three phases to be eligible to participate in practice when practice for the Event begins or have these requirements waived by INDYCAR. No Rookie Driver will be eligible for a Qualifications attempt prior to completing the final phase.

4.3.2.5.6. Drivers will be permitted time to practice after the completion of one phase and before beginning the next phase.

4.3.2.5.7. Refresher Test – If a Driver has not participated in an oval Event in the NTT IndyCar Series since the prior year's Indianapolis 500<sup>®</sup> Mile Race, INDYCAR will determine if any additional testing shall be required. In addition to Car control, placement and interaction with other Cars on-Track to the satisfaction of INDYCAR, the refresher test consists of the 30 laps that make up the second and third phases of the ROP. No such Driver will be eligible for a Qualifications attempt prior to completing the refresher test.

4.3.2.5.8. ROP Schedule – Except as otherwise approved by INDYCAR, ROP shall only be conducted during the times/dates designated by INDYCAR.

4.3.3. Provided INDYCAR approves the substitution and the change takes place prior to the parade and pace laps, the original Driver entered for the Race may be substituted by:

4.3.3.1. **Oval Events** – Another Driver who has already participated in practice, or a special session for the current Event.

4.3.3.2. **Road / Street Course Events** – Any other Driver.

## 5. ENTRIES

### 5.1. General

5.1.1. All Entry applications shall be completed on forms in the manner required by INDYCAR and shall be subject to the approval of INDYCAR. Entries are not transferable without the prior written approval of INDYCAR.

### 5.2. Entrant

5.2.1. An approved Entry serves as the authorization to compete in a specific Event or Events(s) on behalf of the specific Entrant to whom the Car number is assigned and acknowledgement of an agreement to the Rules.

5.2.2. If an individual/entity participates in any Event without having properly submitted fully executed Entry form materials, the individual/entity, by such participation, nevertheless agrees that the individual/entity is subject to all Rules and all statements, releases and obligations appearing in the Entry form materials for the Event, as if the individual/entity had properly submitted fully executed Entry form materials.

5.2.3. In recognition of the support of racing fans and efforts and monies expended by sponsors, INDYCAR and Event Promoter in connection with the Events, Entrant, on behalf of Entrant Group, agrees to participate in any and all portions of on-Track Events in which Entrant has submitted and INDYCAR has approved, an Entry. Entrant agrees not to engage alone or with others in tactics which would disrupt or delay the on-Track Events and to cooperate fully with ceremonies preceding, during and following the on-Track Event and to refrain from any conduct which would disrupt or detract from such ceremonies.

5.2.4. Entrant understands and agrees that INDYCAR has the right at any time to withdraw the privileges of participation or otherwise reject, exclude or disqualify any member of Entrant Group, including but not limited to any Car, Driver or other Entrant Participant, if INDYCAR in its discretion determines that rejection, exclusion or disqualification is in the best interest or integrity of INDYCAR, the NTT IndyCar Series or the promotion of Events. Entrant, Driver and any third party they represent, including without limitation other Entrant Participants, shall have no claim for damages or injunctive relief against INDYCAR, any Event Promoter and/or their representatives by reason of such rejection, exclusion or disqualification.

### 5.3. Car

5.3.1. Participation of a Car in an Event – In order to participate in an Event, the Car must be properly entered and be designated and explicitly identified by Car number on only one Entry form for that Event. Notwithstanding any prior INDYCAR approval, any Car participating in an Event while in noncompliance with the above requirements may be disqualified and any Competitor who causes such noncompliance may be disqualified and/or otherwise penalized by INDYCAR.

5.3.2. Once an Event has begun, Entrants' Car(s) must remain on the Race Location grounds unless otherwise approved by INDYCAR.

#### 5.3.3. Car Registration

5.3.3.1. Car Names – A Car must have a name that shall be identified on the Entry form. The Entrant represents to INDYCAR that it has the right to use that Car name. The Car name is subject to the approval of INDYCAR and must not exceed 35 characters, including all spaces and punctuation.

5.3.3.2. A Car may compete only in the Events in which the Car is entered. The Entry form must establish the Entrant's right to enter the Car in the Event and include proof of ownership of the Car acceptable to INDYCAR. INDYCAR will use a Car number and Dallara assigned chassis registration number to identify each Car.

5.3.3.3. Car Number – INDYCAR will assign to each Entrant License (not Driver License) a unique Car number. The Car number may consist of a maximum of two digits. No Car number may begin with the 0 digit. Car number 1 will be reserved for the defending Entrant (not Driver) series champion.

5.3.3.3.1. All Car numbers are owned by INDYCAR. An Entrant may be granted the use of a Car number.

5.3.3.3.2. All Entrants desiring a particular Car number must make a written request to INDYCAR. INDYCAR will not guarantee a request will be granted.

5.3.3.3.3. After a Car number is assigned to a particular Entrant License, it will remain with that Entrant License until that Entrant is no longer a Full Season Entrant, provided that Entrant enters a Car and displays the Car number on the Car at each Event. If the Entrant does not enter a Car and/or display the Car number on the Car at an Event, INDYCAR may reassign the Car number.

5.3.3.3.4. The required Car number locations must be clearly visible as determined by INDYCAR. The required number must be a solid color (up to 10% transparency may be applied for graphics), one (1) inch in thickness, positioned on a solid single colored background and maintain a two (2) inch area around the numbers, free of all other decals, trim, color, advertisement and decorations. The number is not required to be continuous in nature, or a traditional font. Trim color around the number is permitted provided it does not distort the readability number font and does not apply toward the height or width requirement.

5.3.3.3.5. Nose – The minimum height of the numeric digit must be nine (9) inches. A portion of the Car number on the nose must be located on the front shock cover. (See illustration)

5.3.3.3.6. Headrest – The Car number must be marked on the rear of the headrest a minimum dimension of 1 inch by 1 inch.

5.3.3.3.7. Tub – The Car number and Driver's first and last name must be 1 inch tall each. Letters and numbers must be in Impact font, black or white in color and no trim is permitted. This must be located directly behind the headrest.

5.3.3.3.8. All aspects of the Car number including, without limitation, height and width must be approved by INDYCAR prior to use.

**5.3.3.3.9. Car Appearance** – INDYCAR has the right to control the appearance of Cars to distinguish one Car from another. This may include, without limitation Car color. Cars are required to display significantly different colors. INDYCAR requires different color schemes on any four of the following seven parts:

- a) Mirror housing
- b) Roll hoop cover
- c) Roll hoop camera cover
- d) Front and rear wing end fences
- e) Leading edge of the front wing
- f) Leading edge of the rear wing
- g) Attenuator

**5.3.3.3.10. Rookie Driver Designation** – Rookie Drivers must have the rear of the attenuator displayed in a fluorescent yellow at all Events (see illustration below).

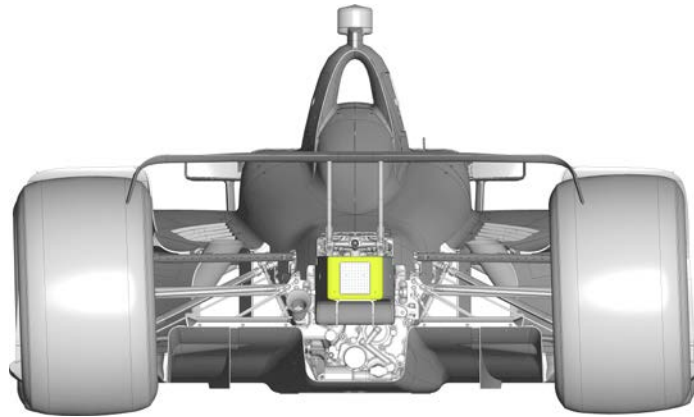

**5.3.3.3.11. Supplier Branding** – Entries must display all required supplier logos per Rule 13.1.1 and the INDYCAR Style Guide, which can be accessed at [epaddock.indycar.com](http://epaddock.indycar.com) (see illustration below).

**Car Number and Supplier Branding (Chevrolet) Speedway**

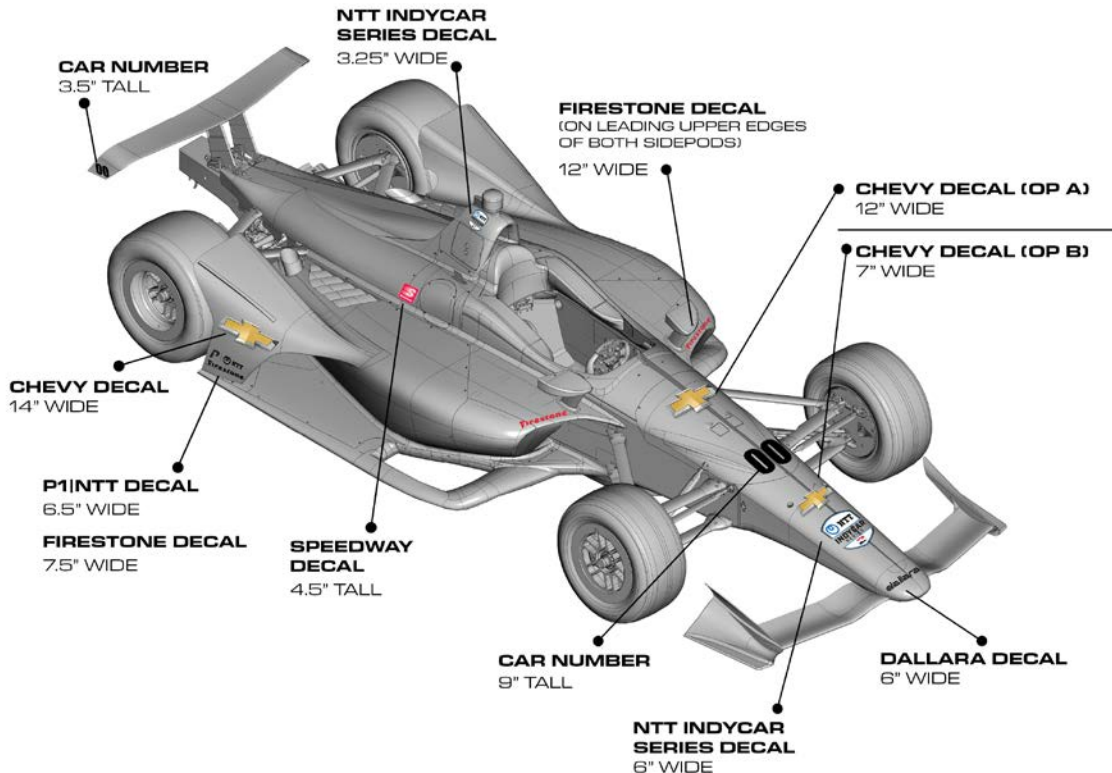



**Car Number and Supplier Branding (Chevrolet) Road Course/Street Course/Short Oval**

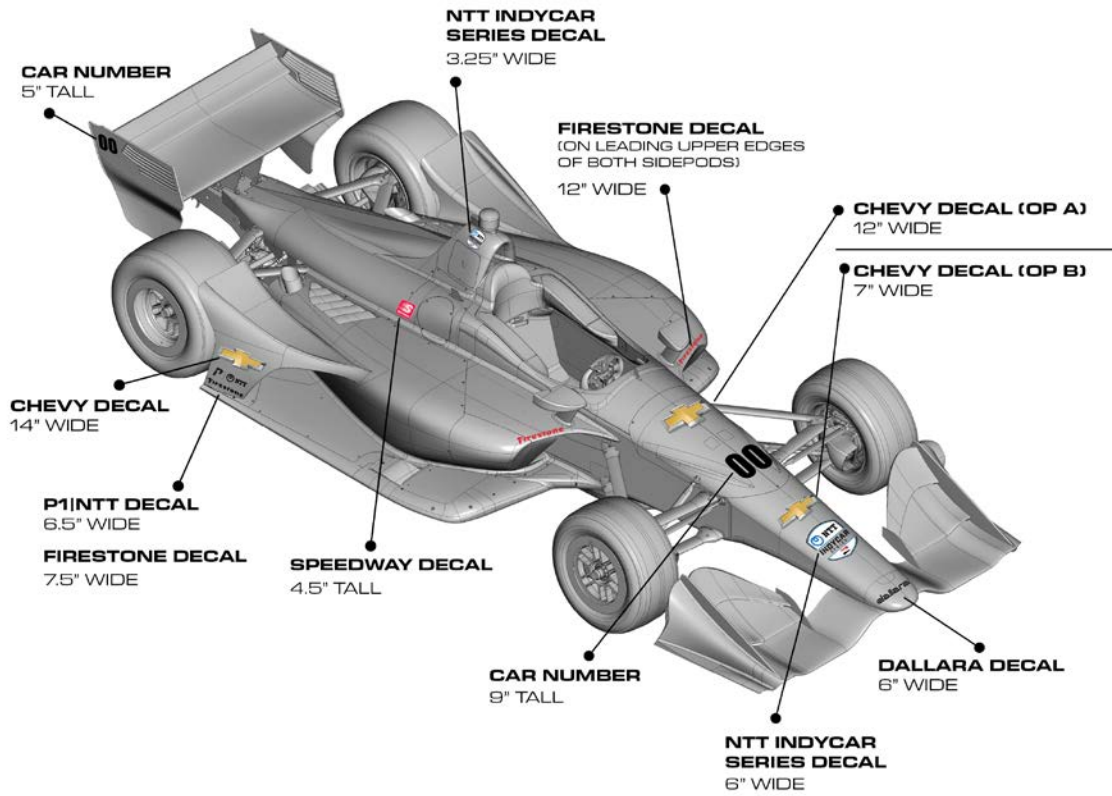

**Car Number and Supplier Branding (Honda) Speedway**

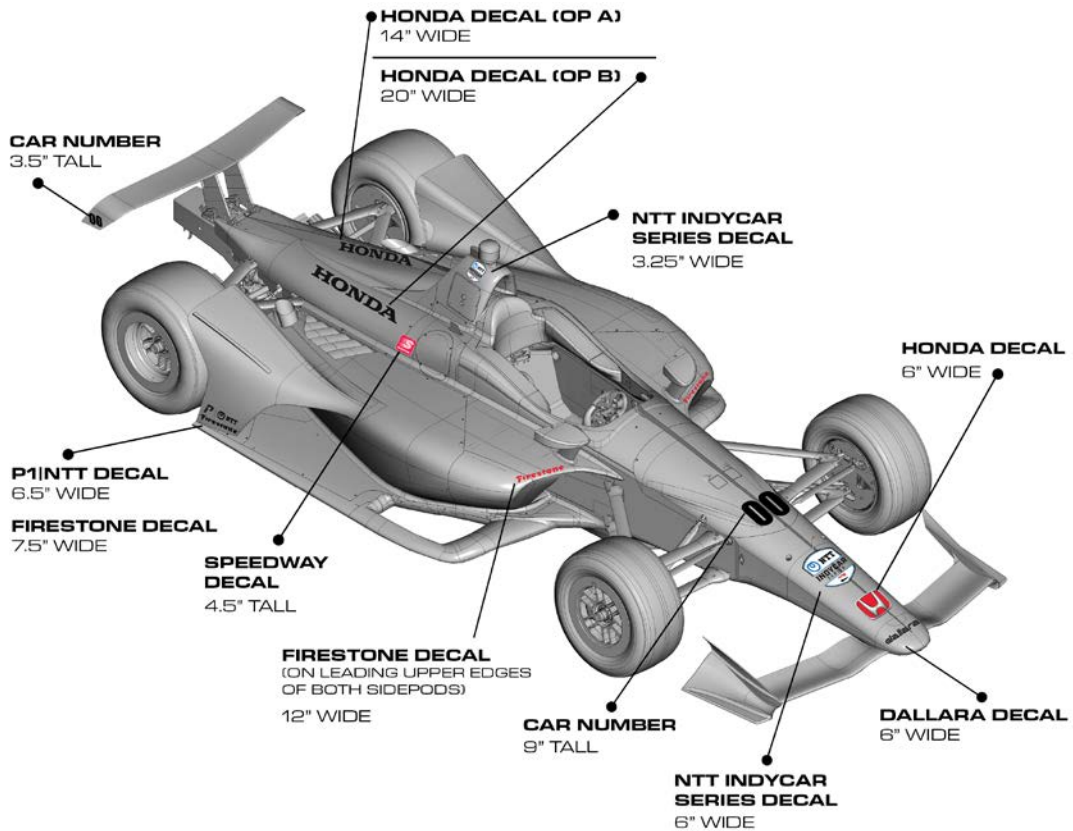

## Car Number and Supplier Branding (Honda) Road Course/Street Course/Short Oval

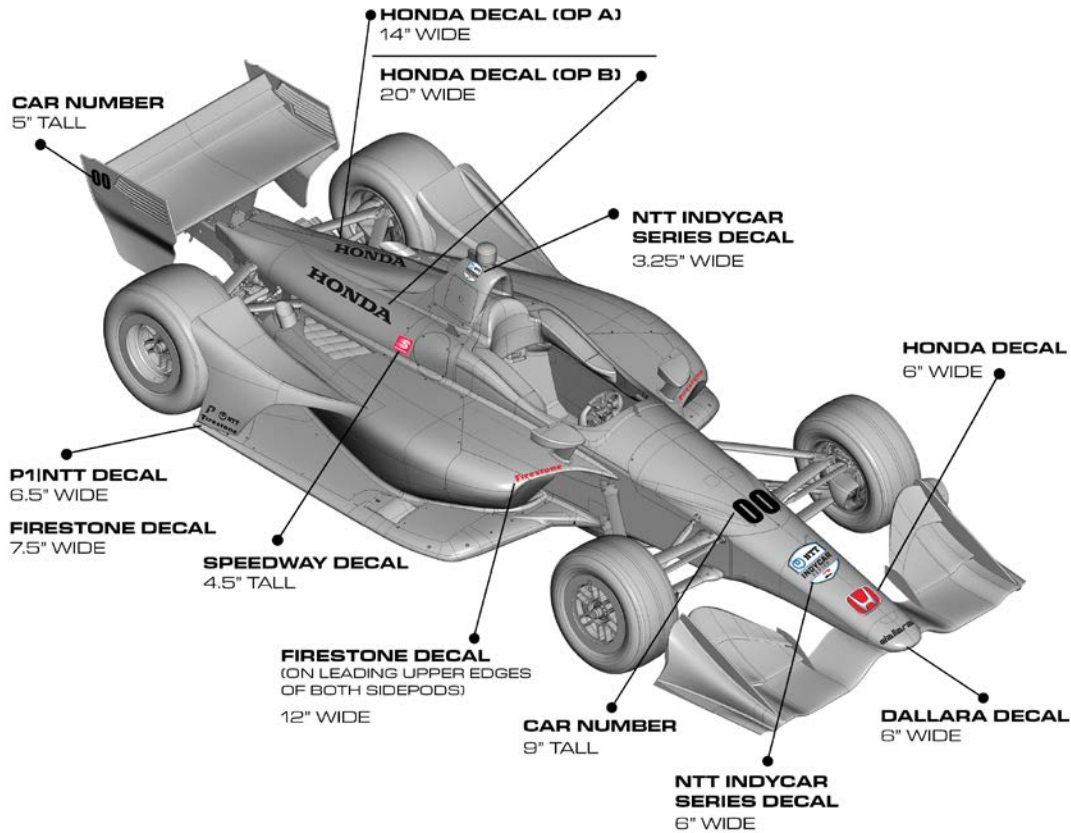

### 5.3.4. Car Substitution during an Event – Backup Cars

- 5.3.4.1. An Entrant's Backup Car must remain on the transporter without an Engine installed. The Backup Car may only be removed, have an Engine installed and used in any on-Track activities during the Event with prior approval by INDYCAR.
- 5.3.4.2. An Entrant is permitted to remove its Backup Car from its transporter and install an Engine, provided the Entrant is scheduled to participate in another INDYCAR-approved activity within the next 7 days.
- 5.3.4.3. For international Events, INDYCAR may require engines be installed in all Backup Cars as determined by space availability.

### 5.4. Chief Mechanic

- 5.4.1. Each Entry must have a chief mechanic.
- 5.4.2. The chief mechanic is responsible for the Car complying with the Rules.
- 5.4.3. The chief mechanic must accompany the Car during all technical inspection processes.
- 5.4.4. Entrant agrees its chief mechanic shall serve as an authorized corporate representative regarding all issues related to technical inspection and communication with INDYCAR.
- 5.4.5. An Entrant shall replace its chief mechanic if INDYCAR determines that the chief mechanic is not sufficiently qualified.

### 5.5. Spotters

- 5.5.1. Oval Events, except the Indianapolis 500<sup>®</sup> [and Pocono Raceway](#)– One (1) spotter is required during all on-Track activity, excluding Qualifications.
- 5.5.2. Indianapolis 500<sup>®</sup> [and Pocono Raceway](#)– Two (2) spotters are required during all on-Track activity, excluding Qualifications.
- 5.5.3. A spotter must:
  - 5.5.3.1. be in the INDYCAR-specified location(s),
  - 5.5.3.2. have a radio capable of communicating with the Driver and a Member in the Entrant's Pit Box,
  - 5.5.3.3. monitor the Team Broadcast Frequency,
  - 5.5.3.4. have the required memberships, and
  - 5.5.3.5. be registered with INDYCAR.

### 5.6. Fees

Entry fees must be paid in good funds as directed by INDYCAR.

### **5.7. Deadline**

The Entry deadline shall be stated on the Entry form. Unless otherwise specified on the Entry form, the hour of closing shall be 5pm E.T. on the day of the Entry deadline. INDYCAR may accept or refuse to accept late Entries. Late Entrants, if accepted, may be penalized by INDYCAR.

### **5.8. Electronic Entries**

An Entry by electronic mail or other means delivered by the closing of the Entry deadline may be accepted, provided it is subsequently accompanied by the Entry fee within 48 hours of INDYCAR's receipt of the Entry or as otherwise directed by INDYCAR.

### **5.9. Reopening of Entries**

If INDYCAR postpones an Event, INDYCAR may authorize the reopening of Entries. Reopened Entries shall close not less than forty-eight (48) hours before the declared starting time of the postponed Event.

### **5.10. Failure to Participate**

Any Driver, Entrant, or other Member who by Entry form or other means has agreed to participate in an Event may be penalized for failing to participate in any portion of such Event.

### **5.11. Entry Change**

All changes to an approved Entry form shall be completed on INDYCAR provided forms and subject to approval by INDYCAR prior to the Entrant's Car participating in any on-Track activities.

## 6. TESTING

### 6.1. General

6.1.1. All Tests must comply with the Rules.

6.1.2. Costs – An applicant shall pay all costs incurred by INDYCAR relating to any tests approved by INDYCAR.

### 6.2. Effective Dates

6.2.1. This Rule 6 applies from after the final Race of a given Racing Season through the final Race of the following Racing Season.

### 6.3. Testing Blackout Periods

6.3.1. Except as otherwise provided in this Rule, on-Track Testing or straight-line Testing may not occur, or is “blacked out”:

6.3.1.1.1. Within seven (7) calendar Days of the start of any on-Track activity at any Race Event (if the practice session one (1) is on Friday, Testing must be done by the completion of the Day on Thursday the week prior).

6.3.1.1.2. During the following periods:

6.3.1.1.3. September 17, 2018 – September 30, 2018,

6.3.1.1.4. November 19, 2018 – November 26, 2018 (Thanksgiving), and

6.3.1.1.5. December 15, 2018 – January 6, 2019 (Holiday)

6.3.1.1.6. The only exceptions to the blackout are:

6.3.1.1.7. Open Tests; and,

6.3.1.1.8. March 1, 2019 – March 4, 2019.

6.3.2. Full-size wind tunnel Tests may not occur or are “blacked out” during the following periods (~~excluding Engine Manufacturers~~):

6.3.2.1.1. September 17, 2018 – September 30, 2018,

6.3.2.1.2. November 19, 2018 – November 26, 2018 (Thanksgiving), and

6.3.2.1.3. December 15, 2018 – January 6, 2019 (Holiday)

### 6.4. Application and Reporting Process

6.4.1. An application for each on-Track Test, full-size wind tunnel Test or straight-line Test must be submitted to INDYCAR via IRIS for approval.

6.4.2. Applications and notices are due:

6.4.2.1.1. On-Track Tests and straight-line Tests: thirty (30) calendar Days before the Test, and

6.4.2.1.2. Full-size wind tunnel Tests: seven (7) calendar Days before the Test.

6.4.3. INDYCAR may place conditions on its approval of an on-Track, full-size wind tunnel Test or straight-line Test, including requiring an Official to attend a Test.

6.4.4. Cancellations must be submitted to INDYCAR via IRIS a minimum of seventy-two (72) hours before an on-Track Test or straight-line Test. A Member is responsible for all non-refundable INDYCAR expenses.

### 6.5. Test Participants

6.5.1. Only Members may Test.

6.5.2. Entrants

6.5.2.1.1. An Entrant must have an Entrant License and membership in INDYCAR for the NTT IndyCar Series.

6.5.3. Drivers

6.5.3.1.1. A Driver must have a Driver’s License and membership in INDYCAR for the NTT IndyCar Series.

6.5.3.1.2. A Driver may be a Driver other than the Entrant’s current Driver(s).

6.5.3.2. Unless otherwise specified, any combination of Drivers may Test.

6.5.4. Manufacturers

6.5.4.1.1. A Manufacturer must have an Associate’s membership in INDYCAR for the NTT IndyCar Series.

6.5.5. All Other Individuals and Entities

6.5.5.1. All other individuals and entities must have memberships in INDYCAR for the NTT IndyCar Series.

## 6.6. Approved Testing

6.6.1. Team Tests, full-size wind tunnel Tests and straight-line Tests: Each Team with one (1) or more Full Season Entrants has a combined total of ~~five (5)~~three (3) Test Days.

6.6.1.1. Team Tests, full-size wind tunnel Tests and straight-line Tests:

6.6.1.1.1. An Entrant must allow other Entrants to attend a Team Test, up to the maximum number allowed by a venue.

6.6.1.1.2. A full-size wind tunnel Test is a maximum of twelve (12) hours within any twenty-four (24) hour period.

6.6.1.1.3. Test Days must be utilized between October 1, 2018 and March 4, 2019.

6.6.2. Open Tests:

6.6.2.1. The Open Tests are:

6.6.2.1.1. February 12-13: Circuit of the Americas (Austin, Texas)

6.6.2.1.2. April 24: Indianapolis Motor Speedway (oval)

6.6.2.1.2.1. Eligible participants:

6.6.2.1.2.1.1. All current Indianapolis 500® Entries; and

6.6.2.1.2.1.2. Full-Season Rookies who have completed a Superspeedway ROP and have received INDYCAR approval. Drivers approved to participate will not be eligible for any additional ROP activities.

6.6.2.1.3. September 19: WeatherTech Raceway Laguna Seca (Salinas, California)

6.6.2.2. All Leaders Circle Entrants must attend Open Tests unless otherwise approved by INDYCAR. Any unapproved failure to attend an Open Test results in a \$5,000 fine and loss of one (1) Team Test Day.

6.6.2.3. All other Entrants may be invited to attend Open Tests subject to INDYCAR approval and Tire availability with Firestone.

6.6.3. Rookie Driver Tests:

6.6.3.1.1. All Rookie Driver Tests:

6.6.3.1.2. For purposes of this Rule, Rookie Driver status is determined after the completion of the final Race.

6.6.3.1.3. All Rookie Drivers must complete ROP on an INDYCAR-approved Oval before competing in an Oval Event. An Official must be present. This ROP does not count against the allotment of Team Tests or Rookie Driver Tests.

6.6.3.1.4. At Oval venues only (excluding Indianapolis ROP), a veteran Driver may have the first six (6) laps or two (2) outings, whichever occurs earlier, of on-Track activity to establish the Car set-up or the baseline for the Rookie Driver.

6.6.3.1.5. All Indianapolis 500® Rookie Drivers must complete the Indianapolis 500® ROP at the Indianapolis Motor Speedway on the specified date or have requirements waived by INDYCAR.

6.6.3.1.6. Full-Season Rookie Driver Tests:

6.6.3.1.7. Each Full Season Entrant with Full-Season Rookie Driver(s) is allotted an additional two (2) Test Days. Multiple Full-Season Rookie Drivers may run each day.

6.6.3.1.7.1. Test days may only be utilized by the entered Full-Season Rookie Driver(s).

6.6.3.1.7.2. Test days must be utilized between October 1, 2018 and September 11, 2019.

6.6.3.1.8. Each Full-Season Entrant with Full-Season Rookie Driver(s) is allotted one Driver evaluation day, which must be utilized on a Road Course.

6.6.3.1.8.1. If a Rookie Driver completes a Driver evaluation test and consequently signs a Full-Season agreement with same Entrant, this test day will be considered utilized.

6.6.3.1.8.2. Test day must be utilized between October 1, 2018 and March 4, 2019.

6.6.3.1.9. Indianapolis 500® Only Rookie Drivers:

6.6.3.1.10. Rookie Drivers have one (1) Test Day for ROP at a Super Speedway before the Indianapolis 500® Event.

6.6.4. Non-Full-Season Rookie. Driver Evaluations, Injured and/or Returning Drivers Tests

6.6.4.1.1. An Entrant has additional Test Day(s) as approved by INDYCAR on a case-by-case basis.

6.6.4.1.2. Test Day(s) may not take place at a Race Location prior to the current season's scheduled INDYCAR Race event at that location. Exemptions may be allowed with INDYCAR approval.

6.6.5. Indy Lights Series Driver Tests:

6.6.5.1.1. Full-Season Entrants in the NTT IndyCar Series have an additional one (1) Test Day for the purpose of Testing a Current Indy Lights Series Driver(s) in a Car. Participating Current Indy Lights Driver(s) must receive prior INDYCAR approval.

6.6.5.1.2. If a Team participates with two (2) or fewer Full-Season Entrant(s) in the Indy Lights Series, the Team may use a maximum of two (2) Cars during the Test.

6.6.5.1.3. If a Team participates with three (3) or more Full-Season Entrant(s) in the Indy Lights Series, the number of Cars testing may not exceed the number of the Teams Full-Season Indy Lights Series Entrants.

**6.6.5.1.4.** Entrants may use multiple Current Indy Lights Series Drivers.

**6.6.5.1.5.** Test Days must be utilized between October 1, 2018 and September 11, 2019.

**6.6.6.** Indy Lights Series Team Test:

**6.6.6.1.1.** Each Team with at least one (1) Full-Season Entrant in the NTT IndyCar Series and at least one (1) Full-Season Entrant in the Indy Lights Series has an additional one (1) Team Test Day.

**6.6.6.1.2.** The Team Test Day is earned and may be used by a Team once the Indy Lights Series Team has participated in its fifth (5th) Indy Lights race and must be utilized by September 11, 2019.

**6.6.6.1.3.** The NTT IndyCar Series Entrant and the Indy Lights Series Entrant must be the same Member, and the Team must submit a total of only one (1) Entrant License/membership application. The Race Event applications for each series must list the same Entrant name (with the exception of the d/b/a) and Entrant tax identification number. For purposes of this Rule, Entrant is decided without regard to Car number.

**6.6.7.** New Team Tests:

**6.6.7.1.1.** A new Team has an additional two (2) Team Test Days, as approved by INDYCAR.

**6.6.7.1.2.** The Team Test Days must be utilized between October 1, 2018 and September 11, 2019.

**6.6.8.** Media/TV/Photograph Tests:

**6.6.8.1.1.** Each Entrant has additional Test Day(s) for promotion, sponsor commercial or special marketing needs, subject to INDYCAR approval.

**6.6.9.** Tire Manufacturer Tests

**6.6.9.1.1.** Firestone will invite a minimum of two (2) Cars per Test for INDYCAR-approved Tire Testing.

**6.6.9.1.2.** Each Team may only participate in a maximum of two (2) Tire Manufacturer Tests.

**6.6.9.1.3.** INDYCAR may invite additional Entrants to test during Tire Tests. Additional Entrants will not be charged a Tire or Team test day.

**6.6.10.** Engine Manufacturer Tests

**6.6.10.1.1.** An Engine Manufacturer Test is a Test organized by an Engine Manufacturer to which selected Entrants are invited to participate.

**6.6.10.1.2.** Each Engine Manufacturer is allotted ~~two (2)~~one (1) Test Day.

**6.6.10.1.3.** Test Day may not be utilized at INDYCAR Open Test locations (COTA / IMS oval / Laguna Seca)

**6.6.10.1.4.** An Engine Manufacturer organizing the Test must permit any Teams using its Engines to also attend the Test in addition to the Teams invited.

**6.6.10.1.5.** All Teams using the Engine of the Engine Manufacturer organizing the Test will not be charged a Team Test Day for such Engine Manufacturer or Team Testing.

**6.6.10.1.6.** An Engine Manufacturer must permit all Entrants of the other Engine Manufacturer(s) to attend the Test for Testing purposes. Teams choosing to participate will be charged with the appropriate type of Test Day for such Testing.

**6.6.10.1.7.** Test Days must be utilized between October 1, 2018 and September 11, 2019.

**6.7.** Tires

**6.7.1.** Tires from a Testing allotment are subject to availability with Firestone.

**6.7.2.** A Team is allotted five (5) sets of Tires per Day for use in all Tests (excluding Open Tests).

**6.7.3.** Full-Season Entrant

**6.7.3.1.** Each Full-Season Entrant is allotted fifteen (15) sets of Tires for use in Team Tests, full-size wind tunnel Tests and straight-line Tests.

**6.7.4.** If an Entrant does not use all of its allotted Tires during a Race Event, any new/unused Tires are added to the Entrant's Test allocation. These Tires are not Race Location specific and are subject to availability. New/unused sets of alternate Tires are added to the Entrant's allotment as primary Tires.

**6.7.5.** Open Tests

**6.7.5.1.** For Open Test Tire allotment, please refer to Tire Allotment chart in Chapter 15 - Tires.

**6.8.** Locations

**6.8.1.** Tests may occur at the following INDYCAR-approved locations:

**6.8.1.1.** All current NTT IndyCar Series United States Race Locations, except Street Courses

**6.8.1.2.** Road Courses

**6.8.1.2.1.** Homestead Miami Speedway

**6.8.1.2.2.** Sebring International Raceway

**6.8.1.2.3.** Watkins Glen International

6.8.1.2.4. NOLA Motorsports Park

6.8.1.2.5. [Sonoma Raceway](#)

6.8.1.3. Ovals

6.8.1.3.1. Chicagoland Speedway

6.8.1.3.2. Homestead Miami Speedway

6.8.1.3.3. Kentucky Speedway

6.8.1.3.4. [ISM Raceway](#)

6.8.1.4. Other venues as pre-approved by INDYCAR in writing.

6.8.2. Straight-line Tests at any other locations are not eligible for INDYCAR's participant accident insurance coverage.

## 6.9. Additional Testing Limitations

6.9.1. Testing for non-Full-Season Entrants shall be at the discretion of INDYCAR.

6.9.1.1. Members agree to provide a minimum of one (1) hour of media availability per on-Track Test Day.

6.9.1.2. Test Days and/or mileage may only be used by the specified Entrant. They must not be sold or assigned.

6.9.1.3. An INDYCAR-approved private Test facilitator must be present at all on-Track Tests, except as otherwise approved by INDYCAR. Each Entrant agrees to cooperate with the directions of the private Test facilitator.

6.9.2. Model wind tunnel Testing is permitted.

6.9.3. Rig-type Testing is permitted, provided the tires are not rotating.

6.9.4. Members must not Test in simultaneous on- Track activity with any non-NTT IndyCar Series vehicles including Indy Lights Series vehicles.

## 6.10. Violations

6.10.1. Violations of the Testing Rule will result in a loss of up to fifty (50) Entrant points, fifty (50) Driver points, fifty (50) Engine Manufacturer points, and/or a fine not to exceed \$500,000.

## 7. AT TRACK PROCEDURES

### 7.1. On-Track Conditions

7.1.1. INDYCAR determines the Track Condition. Track Conditions include the following:

7.1.2. Green Condition – The Green Condition signifies racing conditions.

7.1.3. Yellow Condition – The Yellow Condition signifies caution.

7.1.3.1. Oval Events – All Drivers shall reduce speed immediately, proceed with caution, maintain position and yield to safety vehicles and/or personnel.

7.1.3.1.1. Practice/Qualifications – Lap timing ceases at the declaration of a Yellow Condition. Cars are required to return to their respective Pit Boxes.

7.1.3.2. Road/Street Courses (Local) – All Drivers shall reduce speed by a minimum of 15% or greater if conditions warrant and be prepared to stop. Overtaking is not permitted between the first Yellow Condition and the subsequent Green Condition.

7.1.3.3. Race

7.1.3.3.1. The Pit Lane is closed upon a Full Course Yellow Condition.

7.1.3.3.2. Any Car with the nose of the Car past the Pit Commitment Line before the Yellow Condition may enter its Pit Box.

7.1.3.3.3. Any Car with the nose of the Car not past the Pit Commitment Line before the Yellow Condition should remain on the Racing Surface. If that Car enters Pit Lane, it may drive through and rejoin on the Track according to the Car's Blend Line order. If the Car enters its Pit Box:

7.1.3.3.3.1. Damage may be repaired,

7.1.3.3.3.2. If a Tire is damaged, all Tires may be changed.

7.1.3.3.3.3. If low on fuel, the fuel probe may be plugged in for a maximum of two (2) seconds.

7.1.3.3.3.4. The Car will restart from the rear of the Restarting Lineup.

7.1.3.3.3.5. INDYCAR may further penalize any Competitor who performs any additional work on a Car.

7.1.3.3.4. INDYCAR will dispatch the Pace Car to pick up the Race leader. Cars must form a single file line and pack up behind the Pace Car. INDYCAR may allow one or more Cars to pass any Car not packing up immediately.

7.1.3.3.5. INDYCAR signals when the Pit Lane is open.

7.1.3.3.6. Cars may enter the Pit Lane upon the signal.

7.1.3.3.7. Cars exiting Pit Lane rejoin on the Track according to their Blend Line order.

7.1.3.3.8. A Car may pass another Car, only if:

7.1.3.3.8.1. Both Cars are in Pit Lane boundaries,

7.1.3.3.8.2. The other Car is stopped on the Track,

7.1.3.3.8.3. The Driver of the other Car has waved by all of the passing Cars in an INDYCAR-specified location and approved by INDYCAR, or

7.1.3.3.8.4. The other Car is not maintaining the Pace Car speed only upon direction of INDYCAR.

7.1.3.3.8.5. The other Car is involved in an incident and/or incident in progress. Final determination of ordering of Cars involved in an incident to be made by INDYCAR. INDYCAR's decision is not subject to review and/or appeal.

7.1.3.4. A Car must not use Pit Lane to improve its position relative to the Pace Car or any Car remaining on the Racing Surface, but a Car may improve its position relative to other Cars in Pit Lane.

7.1.3.5. INDYCAR shall determine if the leader or any other Car fails to pace the Race as directed. INDYCAR shall determine the penalty. Such decision is not subject to review and/or appeal.

7.1.3.5.1. Abandonment of Procedures – INDYCAR may abandon any or all Yellow Condition procedures. Procedures that may be abandoned include, but are not limited to:

7.1.3.5.2. opening the pits ([Rule 7.1.3.3.5.](#)),

7.1.3.5.3. the wave-by ([Rule 7.7.1.1.](#)) and/or,

7.1.3.5.4. moving cars not on the lead lap to the rear of the restart lineup ([Rule 7.7.1.2.](#))

7.1.3.5.5. INDYCAR will announce over the Team Broadcast frequency any changes to the standard Yellow Condition procedures prior to them being abandoned.

7.1.4. Red Condition – The Red Condition signifies suspension of on-Track activities. All Drivers are required to slow to caution speed, maintain position and yield to safety vehicles and personnel. All timing and scoring shall be suspended at the declaration of the Red Condition.

7.1.4.1. Practice/Qualifications – Cars are required to return to their Pit Boxes.

7.1.4.1.1. Practice (Road/Street Courses) – Any Driver involved in an incident that results in the declaration of a Red Condition will be subject to the following:

- a) [A Driver involved in an incident that results in the declaration of Red Condition during a practice session will be assessed a penalty of five \(5\) minutes of Green Condition time during that session.](#)



~~b) —Any time a Driver is involved in more than one (1) incident that results in the declaration of Red Condition during the same practice session, that Driver will be assessed a penalty of ten (10) minutes of Green Condition time during that session for second and following incident(s).~~

~~e)b)~~ Any Driver requiring the assistance of Track Safety/Officials during the Red Condition will be subject to Rule 7.1.4.1.1a.

**7.1.4.2. Parade and Pace Laps / Race** – The following procedures will be in effect:

- a) Competitors must proceed cautiously to a location designated by Officials. The Pit Lane is declared to be closed in a manner consistent with Rule 7.1.3.3.
- b) Two (2) crew members are allowed over the wall to attend to the Car and Driver.
- c) Unless otherwise approved by INDYCAR, the work permitted on Cars while in the designated location consists of plugging in a booster battery, applying towels to bodywork, providing the Driver a drink bottle and fan, and placing fans in the radiator boxes and brakes ducts for cooling. Cars must return to their Pit Boxes for any additional work.
- d) Items which may produce a safety issue must be repaired, replaced and/or removed at the direction of INDYCAR. Cars must return to their Pit Boxes for work.

**7.1.4.2.1.** INDYCAR approved work performed on a Car while under a Red Condition, including under Rule 7.1.4.2.d, will result in the Car being placed at the rear of the Restarting Lineup.

**7.1.4.2.2.** If a Car is in its Pit Box, behind the pit wall or in the garage when the Red Condition is declared, all work must stop until the Red Condition has been withdrawn.

**7.1.4.2.3.** If a Car cannot proceed from the Track to Pit Lane, it must return to its Pit Box when able to do so, and no work may be performed until the Red Condition has been withdrawn.

**7.1.4.2.4.** Unapproved work performed on a Car not related to INDYCAR approved safety issues while under a Red Condition will result in a minimum two (2) lap penalty, which will be enforced in a manner determined by INDYCAR.

**7.1.4.2.5.** Red Condition – intent to restart the race on the same day – Cars may be moved to an impound area

**7.1.4.2.6.** Only the following work may be performed:

**7.1.4.2.6.1.** Booster battery connected

**7.1.4.2.6.2.** Car radio turned off

**7.1.4.2.6.3.** Car cover must be installed

**7.1.4.2.6.4.** INDYCAR will set time windows in which Cars may be started to maintain Engine temperatures. INDYCAR will consider ambient temperature for this process. These set windows will be the only approved times Engines may be started.

**7.1.4.2.6.4.1.** Any Car requiring an Engine start outside of set windows may do so only with INDYCAR approval and will be moved to the rear of the Restarting Lineup per Rule 7.7.2.6.1.

**7.1.4.2.7.** Red Condition – intent to restart the race on following day(s) – Cars may be moved to an impound area

**7.1.4.2.8.** Only the following work may be performed:

**7.1.4.2.8.1.** Battery disconnected

**7.1.4.2.8.2.** Car radio removed

**7.1.4.2.8.3.** Car cover must be installed

**7.1.4.2.8.4.** Two (2) hours prior to the restart of the race Engine, oil and gearbox heaters may be installed

**7.1.4.2.8.5.** All Cars must be started and ready to grid 30 minutes before the restart

**7.1.4.2.9.** Red Condition - Cars released to the Teams – the following procedures will be in effect:

**7.1.4.2.10.** Cars will be taken to the fuel depot; Car's fuel tank will be filled or drained to determine the amount of fuel in the Car.

**7.1.4.2.10.1.** Prior to being gridded for the restart, Entrants must drain the Car's fuel tank and return to the fuel depot to have the previously-determined amount of fuel added to the Car's fuel tank.

**7.1.4.2.10.2.** Violation of Rule 7.1.4.2.10 will result in the amount of fuel being added to the car be cut in half, the Car placed at the rear of the Restarting Lineup, and a 2 (two) lap penalty.

**7.1.4.2.11.** Tire barcodes will be recorded.

**7.1.4.2.11.1.** These tires must be used until scoring resumes and the Pit Lane has been declared open. INDYCAR may approve all Cars to restart the race on a different set or type of tires.

**7.1.4.2.12.** The Car's Engine, gearbox and chassis serial numbers will be recorded.

**7.1.4.2.12.1.** The same Engine, gearbox and chassis must be used for the restart unless otherwise approved by INDYCAR.

**7.1.4.2.13.** INDYCAR may record the aerodynamic configuration of the Car and require the Car to be in the same configuration (excluding wing angles) for the Race restart.

**7.1.4.2.14.** It will be at INDYCAR's discretion whether a Car being repaired on pit lane or in the garage area when the Red Condition is declared will be eligible to continue in the Event.

**7.1.5.** The decision as to whether to declare a Green, Yellow, Full Course Yellow Condition, or Red Condition may not be reviewed and/or appealed.

**7.1.6.** While additional information regarding Track Condition is included in the Flag Code and Track condition lights section for convenience, this information is equally applicable to the other systems of notification (track lights, pit closed lights, team broadcast frequency, track condition radio and instant messaging).

**7.1.7.** Decisions by INDYCAR are effective immediately, regardless of the time the declaration is received by the Competitors. INDYCAR uses multiple systems to notify Competitors of such decisions and will make a reasonable effort to declare Track Condition changes at the time they are determined. All Competitors shall react to the first notification they receive. The systems include the following:

**7.1.7.1.** Track Lights – Green, Yellow and/or Red lights positioned around the Track above the retaining wall adjacent to the debris fence.

**7.1.7.2.** Pit Closed Lights – Yellow lights positioned prior to the Pit Lane entrance to signify the Pit Lane is open or closed. If the light is on, the Pit Lane is closed. If the light is off, the Pit Lane is open.

**7.1.7.3.** "Team Broadcast Frequency" – The radio frequency used by INDYCAR to provide direct communication to Entrants during Events. The spotter (if applicable) and a representative of the Entrant in the Entrant's Pit Box must both monitor the Team Broadcast Frequency. Entrants failing to monitor the Team Broadcast Frequency shall be charged with knowledge of communication on such frequency and are subject to penalty. Member radios, with the exception of Officials, must not be capable of transmitting on this frequency. Members failing to follow directions may be penalized.

**7.1.7.4.** Track Condition Radio ("TCR") – An in-Car warning light system activated by INDYCAR. Radio, harness and antenna must be used as specified by INDYCAR, and the antenna must be mounted in the INDYCAR-specified location.

**7.1.7.4.1.** Oval Events – The TCR signals a Yellow Condition.

**7.1.7.4.2.** Road/Street Course Events – The TCR signals a Full Course Yellow Condition during a Race or Red Condition during practice or Qualifications sessions.

**7.1.7.5.** Instant Messaging – A two-way software messaging system used to provide direct text communication between Entrants and INDYCAR during Events. INDYCAR will send messages where applicable to the Entrant(s). This system may be used to communicate Track conditions, send warnings, penalties, or other information to the Entrant. The system may send information to an individual Entrant or to all Entrants. All Entrants must connect to the INDYCAR-supplied instant messaging system prior to Cars going on-Track.

**7.1.7.5.1.** Instant Messaging Protocol – Entrants may send relevant messages to INDYCAR. Use of the instant messaging system for any reason, including, without limitation, irrelevant, abusive, and/or unnecessarily repetitive messages, will result in monetary penalties. Requests for review of any on-track activity should include specific information (location, approximate time or lap number, car numbers, etc.). Reports without specific details will receive lower priority.

## **7.2. Flag Codes and/or Track Condition Lights (collectively, "Flags")**

**7.2.1.** Green - signifies a Green Condition.

- a) Practice – A practice session has begun.
- b) Qualifications – A Qualifications attempt or segment has begun.
- c) Race – Unless otherwise instructed, a Race has started or re-started.

**7.2.1.1.** Road/Street Courses Events Only – Signifies the end of the Yellow Condition at the point where the flag is displayed or track condition light is illuminated.

**7.2.2.** Yellow – signifies a Yellow Condition. During Road/Street Course Events:

**7.2.2.1.** Local – Signifies the start of the Yellow Condition at the point where the flag is displayed or track condition light is illuminated.

- a) Motionless – A motionless yellow flag means reduce speed, overtaking not permitted, be prepared to take evasive action, a hazard beside or near the edge of the Track or a forewarning of a waved yellow flag ahead.
- b) Waved – A waved yellow flag means reduce speed, overtaking is not permitted, be prepared to take evasive action or stop, a hazard wholly or partially blocking the Track.

**7.2.2.2.** Full Course – Standing double yellow flags displayed at all marshal's posts, including the starter's stand.

**7.2.3.** Black – The Driver shall proceed to his/her Pit Box on the next lap and follow the instructions of INDYCAR.

**7.2.3.1.** INDYCAR may declare a black flag for a Car if it determines that:

- a) Any condition exists which could cause the Driver or the Driver's Car to create a hazard to the Driver or others;
- b) The Driver has violated a Rule; and/or
- c) The Entrant has requested the black flag.

**7.2.3.2.** When a Driver is ordered to his/ her Pit Box because of a hazardous condition of the Driver's Car, the proper repairs must be made and approved by INDYCAR before the Car will be permitted to continue in the Event.

**7.2.3.3.** In the event of a violation of the Rules, the black flag may be declared to impose a penalty (a "black flag penalty") requiring a Driver to:

- a) Drive through Pit Lane at Pit Lane speed limits ("drive through");
- b) Stop in his/her Pit Box ("stop and go"); or
- c) Stop in his/her Pit Box for a prescribed period ("stop and hold").

**7.2.3.4.** INDYCAR shall determine the type of black flag penalty. Service of a black flag penalty for a Rules violation must be initiated under Green Conditions and the penalized Car must cross the Start/Finish line under Green Conditions prior to entering the Pit Lane to serve such penalty except as described elsewhere. The penalized Car shall proceed to the Pit Lane as directed by INDYCAR and may return to competition only upon the declaration of INDYCAR. In the case of a Driver violating the Rules, no work may be performed on a Car during the execution of a black flag penalty. Should any such work occur, the conditions of the penalty are unfulfilled, and the penalty procedure must be executed again in its entirety on a subsequent lap. The penalty may not be reviewed and/or appealed.

**7.2.4.** Black with White Cross – INDYCAR has ceased scoring the Car indefinitely.

**7.2.5.** Blue

**7.2.5.1.** An informational blue flag notifies a Driver that an approaching Car is attempting to overtake.

**7.2.5.2.** At Road/Street Course Events, a command blue flag ordered directly by INDYCAR and displayed from the starter's stand directs a Lapped Car to give way to the overtaking Car within one (1) lap.

**7.2.5.3.** At Oval Events, the informational blue flag will be displayed from the starter's stand as per [Rule 7.2.5.1](#). A command blue flag ordered directly by INDYCAR and displayed from the starter's stand directs a Lapped Car to give way to the overtaking Car within one (1) lap.

**7.2.5.4.** Pit Lane Exit Light – For Road and Street Course Events only, an additional blue light is positioned at the Pit Lane exit and notifies a Driver leaving Pit Lane that a Car on-Track is in close proximity.

**7.2.6.** White

**7.2.6.1.** Oval Event Qualifications – The Car has commenced its last lap.

**7.2.6.2.** Road/Street Course Events – When displayed from a marshal's post, a Car or safety vehicle is not at full speed on the Racing Surface.

a) Motionless – means a slow Car at more than 1/3 racing speed is ahead or as a forewarning of a waved white flag ahead.

b) Waved – a very slow Car at less than 1/3 racing speed is ahead or a moving safety vehicle is ahead.

**7.2.6.3.** All Races – When displayed from the starter's stand, the leader has commenced his/her last lap and will continue to be displayed to all successive Cars as they cross the finish line.

**7.2.7.** White with Red Cross – When displayed from the starter's stand, safety vehicles and/or personnel are on-Track.

**7.2.8.** Alternating Red and Yellow Stripes – Oil, water or other substance has altered the Racing Surface.

**7.2.9.** Checkered – The practice session, Qualifications session or Race is completed. All Drivers must enter Pit Lane after receiving the checkered flag.

**7.2.9.1.** Road/Street Course Events – The checkered flag will be displayed at the marshal's post nearest the alternate start/finish line at the end of practice and Qualifications sessions. All Drivers must immediately enter Pit Lane after receiving the checkered flag at this point.

**7.2.9.2.** Final Practice Sessions – The checkered flag will be displayed at the start/finish line.

**7.2.9.3.** Race – The checkered flag will be displayed to the Race leader at the start/finish line upon the completion of the Race Leader's final lap and will continue to be displayed until each Car running has received the checkered flag.

**7.2.10.** Red – Signifies a Red Condition.

**7.2.10.1.** Unless otherwise declared by INDYCAR, a Race stopped by the declaration of a Red Condition will be considered incomplete unless more than 50% of the scheduled number of laps or unless more than 50% of the declared time limit has been completed by the Race leader. If INDYCAR schedules the continuation of the Race on a subsequent date or a later time, the Race will be restarted beginning with the unfinished portion of the Race.

**7.2.10.2.** If a Race is stopped by the declaration of a Red Condition and more than 50% of the scheduled number of laps or more than 50% of the declared time limit have been completed by the Race leader, INDYCAR may declare the Race complete and final standings will be determined by ranking all Cars in order by total laps completed and sequence of completion through the last official Race lap.

**7.2.10.3.** Officials will make reasonable efforts to restart a Race stopped by the declaration of a Red Condition if the conditions warrant.

**7.2.10.4.** INDYCAR's decision to restart or not to restart a Race stopped by the declaration of a Red Condition may not be reviewed and/or appealed.

**7.3. Timing and Scoring**

**7.3.1.** General

**7.3.1.1.** INDYCAR records the physical order in which each Car crosses each time line, including the Start/Finish Line.

**7.3.1.2.** The start time, number of laps, and/or amount of time of each Race Event will be specified in a bulletin.

**7.3.2.** Race Distance and/or Time Limit

**7.3.2.1.** INDYCAR shall announce the scheduled number of laps and/or time limit prior to the start of a Race; provided, however, INDYCAR may determine that there are time limitations due to weather, curfew, track conditions or otherwise, and INDYCAR may move the start time of a Race, shorten the distance or time of a Race, set a maximum distance or time for a Race, or take such other actions as it deems appropriate.

### 7.3.3. Systems

7.3.3.1. The electronic system is the primary record.

7.3.3.2. INDYCAR may also consult with other Officials, review camera footage, and consider such other data as necessary or appropriate to decide the order of the Cars.

### 7.3.4. Start/Finish Line – The scoring of Cars shall begin at the moment when:

- a) Race – the timing transponder of the lead Car reaches the starting line after the prescribed number of parade and pace laps have been completed.
- b) Practice/Qualifications – the declaration of the Green or Yellow Condition has been given by INDYCAR.

7.3.4.1. Oval Events and Indianapolis 500<sup>®</sup> Mile Race – A single start/finish line will be defined across the Track and extended across the Pit Lane where appropriate, in the immediate area of the starter's stand.

7.3.4.2. Road/Street Course Events – INDYCAR may designate an alternate or separate start/finish lines.

### 7.3.5. Lap Credit

7.3.5.1. A Car is credited with a lap when its timing transponder crosses the Start/Finish Line after completing one (1) entire lap of the Track.

7.3.5.2. A Car is the first (1<sup>st</sup>) Car out of the Race and is awarded the final position based on the following order:

7.3.5.2.1. The Car is listed in the official Qualifications posting, but it is not in position in the Starting Lineup on the Grid and does not start a Race.

7.3.5.2.2. The Car is in position in the Starting Lineup on the Grid, but it does not start the Race,

7.3.5.2.3. The Car drops out during the parade or pace laps, or

7.3.5.2.4. The Car drops out of a Race before completion of the first (1st) lap.

7.3.5.2.4.1. In the event more than one (1) Car is affected in one (1) or more of the above categories, such Cars will be ranked based on their positions in the original Starting Lineup.

7.3.5.3. If a Car returns to Pit Lane under its own power and retires from the Race, INDYCAR may credit the Car with completion of the lap.

7.3.5.4. On the last lap of a Race, a Car will be officially credited with a lap when any part of the Car under its own power crosses the finish line.

7.3.5.5. At Oval Events except for the Indianapolis 500<sup>®</sup> Miles Race, Drivers must not place any of the four wheels of the Car below the solid boundary line at any time.

7.3.5.6. As soon as practical after the completion of an Event, INDYCAR will post the unofficial results.

7.3.5.7. Once the competition review and technical inspection is completed, INDYCAR will post the official results.

7.3.5.8. Final standings will be determined by the sequence in which the Cars completed the scheduled number of laps.

7.3.5.8.1. Except as provided in [Rule 7.3.5.4](#), a Race will be completed by the Race winner at the moment the timing transponder of the Car crosses the start/finish line on the last lap. The Race will be completed by each other Car when the timing transponder of each Car crosses the start/finish line after the Race leader. Scoring will thereafter cease and the Race is completed. INDYCAR's decision may not be reviewed and/or appealed.

7.3.5.8.2. Cars not completing the scheduled number of laps will be ranked in order by total laps completed and sequence of completion, whether the Car is still running or not. INDYCAR shall determine the "reason out" for each Car not listed as running.

### 7.3.6. Ties

7.3.6.1. In the event INDYCAR is unable to conclusively determine any difference in the physical sequence for two or more Cars at the end of a Race, INDYCAR shall determine the finishing positions based upon the Cars' positions at the start/finish line on the prior lap.

7.3.6.2. In the event two or more Cars post the identical number of laps led in a Race, the Car finishing the Race in the higher/highest position will earn the award for most laps led.

7.3.6.3. INDYCAR's decisions are not subject to review and/or appeal.

### 7.3.7. Shortcuts – A Car will not be permitted to advance or maintain its position or time relative to other Cars due to an excursion off the Racing Surface.

7.3.7.1. At least two (2) wheels of a Car must remain on the Track at all times, unless otherwise approved by INDYCAR.

7.3.7.2. Practice/Qualifications – Cars shortcutting the course will have the shortcut lap time invalidated.

7.3.7.3. Race – If evasive action results in the advancement of position or time relative to Cars on-Track, INDYCAR may reposition Cars in accordance with [Rule 9.2.2.4](#).

## 7.4. Communication

### 7.4.1. In-Car Radio & Radio Location

7.4.1.1. The in-Car radio must not be capable of transmitting or receiving in a digital format. Radio transmissions must not be encrypted, scrambled or otherwise modified to affect INDYCAR's ability to record, scan and hear at any time during the Event. Channel

hopping transmissions to or from the in-Car radio are not permitted. All voice radio transmissions to or from the Car must be in the 450.000 MHz to 470.000 MHz range.

**7.4.1.2.** Only the primary and backup frequencies are permitted in the Car radio.

**7.4.1.3.** Radios may not be located in the cockpit area.

**7.4.2.** Frequencies – Each Member transmitting or receiving any signal including, without limitation, voice, data and telemetry, but excluding Internet related Wi-Fi (regulated pursuant to [Rule 7.4.4.](#)) shall:

**7.4.2.1.** Provide the specifications (e.g., frequency, manufacturer, make, model and serial number) of the radio to be used in the Car and otherwise, to the INDYCAR-designated representative prior to their first Event;

**7.4.2.2.** Not password-protect or otherwise affect or limit the INDYCAR-designated representative's ability to scan and hear the radio to be used in the Car at any time;

**7.4.2.3.** Notify the INDYCAR-designated representative immediately upon changing any of the equipment specifications or frequencies of the radio to be used in the Car and otherwise;

**7.4.2.4.** Consent and hereby does consent, to the recording, broadcast and/or rebroadcast by INDYCAR or its designee of any such transmissions through any and all media and for any and all purposes; and

**7.4.2.5.** Comply with all applicable laws regarding such use and indemnify and hold INDYCAR Group harmless with respect to failure to comply with applicable laws, even if the violation involves INDYCAR Group's or its designee's sole or contributory negligence.

**7.4.3.** Radio Communication

**7.4.3.1.** During all on-Track Events, radio communication between the Driver and the Entrant's Pit Box is required at all times.

**7.4.3.2.** Car-to-Car radio communication is not permitted.

**7.4.4.** Wireless Data Frequency ("Wi-Fi") - Each Member transmitting or receiving any signals for wireless data transmissions shall: (i) coordinate and modify frequencies for use with other wireless data networks as specified by INDYCAR; (ii) limit the use of Wi-Fi to hot spot use only (the use of Wi-Fi backhaul and hi gain antennas is not allowed); (iii) comply with all applicable laws regarding such use; and (iv) indemnify and hold INDYCAR Group harmless with respect to failure to comply with applicable laws, even if the violation involves INDYCAR Group's sole or contributory negligence.

## **7.5. Pit Boxes**

**7.5.1.** Non-Indianapolis 500<sup>®</sup> Mile Race Events – Pit Boxes for Race Locations shall be determined based upon the Entrant's position in the Starting Lineup at the previous non-Indianapolis 500<sup>®</sup> Mile Race Location. Pit Boxes will begin with the Pole Position Entrant receiving the Pit Box at pit out and continuing through the Starting Lineup to pit in. Team Pit Boxes will not be averaged.

**7.5.1.1.** If an Entrant did not participate at the prior Race Location, it shall be assigned a Pit Box as follows:

- 1)** Entrant points (behind all Cars in the Starting Lineup at the previous Race Location)
- 2)** Random draw (behind all Cars in the Starting Lineup at the previous Race Location and all Cars with points)

**7.5.1.2.** For the first Race Location of the Racing Season, Pit Boxes shall be assigned based upon prior Racing Season ending Entrant point standings. INDYCAR shall determine an Entrant's eligibility. Entrants without points shall be assigned by the date that Entry was received.

**7.5.1.3.** If Qualifications do not occur at the prior Race Location, Pit Boxes for the subsequent Race Location shall be assigned based upon the Starting Lineup established at the prior Race pursuant to [Rule 8.1.7.](#)

**7.5.1.4.** At a Double-Header Race Location, the Pit Boxes will not be moved between Race One and Race Two. Race Two Qualifications will determine the subsequent Race Location Pit Boxes.

**7.5.1.5.** Indianapolis 500<sup>®</sup>

**7.5.1.5.1.** Practice – Pit Boxes shall be selected by an Entrant based upon the current Entrant point standings following the Streets of Long Beach event. A Team shall average all combinations of its Entrants so as to group them together in Pit Lane. If a Team with points has an Entrant without points, this Entrant will not be calculated into the average. In addition, Partial Season Entrants will not be calculated into the average. INDYCAR shall determine an Entrant's eligibility. Entrants without points shall be ranked at the end of the point standings by date of Entry receipt.

**7.5.1.5.1.1.** Pit Selection shall be conducted in the N1 Office on Thursday, May 9<sup>th</sup> at 1:00 PM (E.T). INDYCAR shall assign a Pit Box for any Entrant not represented at the designated pit selection time and place

**7.5.1.5.1.2.** Following the Indianapolis Road Course Race, Entrants are required to move all Pit equipment to their designated practice Pit Box.

**7.5.1.5.1.3.** Following the conclusion of practice on Friday, May 17<sup>th</sup>, an Entrant must move its pit equipment from the practice Pit Box to the Qualifications Pit Box.

**7.5.1.5.2.** Qualifications – Pit Boxes shall be assigned by INDYCAR based upon the position of the Entrant's primary Car in the initial Qualifications order. The Pit Box for the first primary Car will be the first Pit Box north of Gasoline Alley and continue north through the Qualifications order. Three Cars will be assigned to two Pit Boxes. A Team shall not have the option to average its Entrants. The Pit Box assignments will be distributed after the draw is completed and Entrants may move their pit equipment to their Qualifications Pit Boxes at that time. The same Pit Box assignments will be in place for both Qualifications days.

### 7.5.1.5.3. Post-Qualifications/Race

**7.5.1.5.3.1.** Pit selection order for Cars in the “Fast 9” will be determined by Sunday’s “Fast 9” Qualifications times. “Fast 9” Cars shall select prior to Group One Cars.

**7.5.1.5.3.2.** Pit selection order for Cars in Group One will be determined by Sunday’s Qualifications times.

**7.5.1.5.3.3.** A Team shall have the option to average any combination of its Entrants within the same Qualifications group so as to group them together in Pit Lane. INDYCAR shall determine the time and place for the pit selection. INDYCAR shall assign a Pit Box for any Entrant not represented at the designated pit selection time and place. After the close of Qualifications, an Entry’s pit equipment must be moved from the Qualifications Pit Box to the assigned Pit Box for all post-Qualifications Track activities.

## 7.6. Race Start

**7.6.1.** The Pole Position Car will start from the inside of the front row. Each Car must be in position in the Starting Lineup during the parade and pace laps until declaration of the Green Condition.

**7.6.1.1.** If a Car is not in position prior to the beginning of the pace lap, the Car must start from the rear of the Starting Lineup.

**7.6.1.1.1.** If two or more Cars are affected, INDYCAR decides the positions of the Cars at the rear of the Starting Lineup.

**7.6.1.2.** All other Cars must remain in their positions in the Starting Lineup, unless otherwise directed by INDYCAR.

**7.6.2.** If a Car is in Pit Lane or the garage area and not in position in the Starting Lineup when the scoring for the Race begins, the Car’s first (1<sup>st</sup>) scored lap will start as the Car leaves the Pit Lane.

**7.6.3.** If a Car does not leave the Grid after the command by INDYCAR, it must return to its Pit Box or another area designated by INDYCAR before the beginning of the pace lap.

**7.6.4.** A Pace Car will be used to pace the Cars at the start of the Race. The Pace Car will have its flashing lights on during the parade and pace laps. At the appropriate time, the lights will be turned off, indicating the intent to start the Race the next time across the starting line. The Pace Car will pull off into the designated location.

**7.6.5.** All Drivers must maintain their relative positions until the Green Condition is declared.

**7.6.6.** Upon INDYCAR’s declaration, all Cars must start a Road/Street Course Race on “wet” Tires. Changes may be made to the Cars on the Grid to accommodate the “wet Tires”. After such a declaration has been made, a Car must complete one (1) official lap on “wet Tires”, which must begin under a Green Condition as is determined by INDYCAR. The lap may be completed in Pit Lane even if the Car’s Pit Box prior to the Start/Finish line.

**7.6.7.** During the Parade and Pace laps teams may not add fuel to the car.

## 7.7. Race Restart

**7.7.1.** After a Yellow Condition

**7.7.1.1.** Cars between the Pace Car and the Race leader are waved by:

**7.7.1.1.1.** The wave-by will take place as soon as practical,

**7.7.1.1.2.** The Pit Lane may re-close until the waved-by Cars are packed up,

**7.7.1.1.3.** The Pit Lane will re-open after the full pack-up is established, and

**7.7.1.1.4.** The restart may occur as early as the lap after the Pit Lane has re-opened.

**7.7.1.2.** After the starter gives the “one (1) lap to go” signal and prior to the restart, Cars must line up in single file formation with no gaps or lagging between Cars. In the event of a restart with 15 laps or less remaining, all Cars not on the lead Car lap will be moved to the rear of the Restarting Lineup. In the event of a timed Race, INDYCAR shall announce during the Competition Meeting, the time window at which all Cars not on the lead Car lap will be moved to the rear of the Restarting Lineup.

**7.7.1.3.** At the appropriate time, the Pace Car lights will be turned off, indicating the intent to restart the Race. The leader is required to maintain the pace lap speed until reaching a point designated by INDYCAR near the start/finish line when the leader shall accelerate smoothly back to racing speed and the Green Condition will then be declared. All Car(s) must maintain their respective Track positions until the Green Condition is declared.

**7.7.2.** After a Red Condition – All of the standard restart procedures after a Yellow Condition shall apply with the following exceptions:

**7.7.2.1.** The order will be determined by the physical sequence of the Cars at the declaration of the Red Condition.

**7.7.2.2.** In addition to the crew members permitted under [Rule 7.1.4.2.b](#), one (1) additional crew member is allowed over the wall to bring the starter and/or cart to the Car, when directed by Officials.

**7.7.2.3.** If a Car is unable to restart after the command by INDYCAR, it must return to its Pit Box or another area designated by INDYCAR.

**7.7.2.4.** Provided the Car maintains its lap count relative to the leader, a Car may take its position at any time prior to the start of the “one-to-go” lap. After this time, the Car shall be moved to the rear of the Restarting Lineup.

**7.7.2.5.** The Pit Lane may be opened prior to the “one-to-go” lap.

**7.7.2.6.** Notwithstanding Rule 7.7.2.1., the following reasons may be cause for a Car to be placed at the rear of the Restarting Lineup:

- a) Cars involved in the incident that caused the Red Condition. The decision as to whether a Car has been involved in an incident may not be reviewed or appealed;
- b) Cars stopped on the Track, including the Pit Lane, during the last officially scored lap; and/or
- c) Cars which have performed work under Rule 7.1.4.2.1. and/or Rule 7.1.4.2.4.

**7.7.2.6.1.** The order of Cars placed at the rear of the Restarting Lineup will be in order of total laps completed and sequence of completion.

**7.7.2.7.** Any laps being run under a Yellow Condition will be scored. Any Cars remaining in Pit Lane at the time of a restart may join the Race if approved to compete by INDYCAR.

## **7.8. Mechanical Conditions**

**7.8.1.** INDYCAR shall determine whether a Car involved in a crash or with a hazardous mechanical condition will be permitted to continue in the Event or must first return to the Pit Lane or the garage area for necessary repairs.

**7.8.2.** Parts damaged during the Race may only be replaced by an exact matching part or assembly.

**7.8.3.** INDYCAR shall determine how a disabled Car is removed and where the Car is taken. INDYCAR is not responsible for payment, reimbursement, damage, or loss to any Car as a result of such removal and with respect to the location to which the Car is taken.

**7.8.4.** After any repairs have been completed, the Car is subject to visual or other inspection by INDYCAR prior to and/or during any further competition. If INDYCAR determines that further repairs are warranted, the repairs must be made before the Car is permitted to return to competition.

**7.8.4.1.** Oval Races – Cars being repaired will not be permitted to return to the Race during the last 20 laps of the Race.

**7.8.4.2.** Road/Street Course Races - Cars being repaired will not be permitted to return to a Race during the last 10 laps or 15 minutes of a timed Race.

**7.8.5.** A Car may only receive on-Track assistance as directed by INDYCAR. A Competitor may not leave his/her Pit Box to assist a Car unless approved by INDYCAR.

**7.8.6.** Officials may approve technical or structural changes during technical inspection due to contact, material, or parts failure.

**7.8.7.** These decisions of INDYCAR are final and may not be reviewed and/or appealed.

## **7.9. Performance Standards**

**7.9.1.** INDYCAR may establish a performance standard which all Entries entered in an Event must achieve in order to participate in the Event. In general, Entries must perform within 105% of the Car posting the best time and demonstrate Car consistency, control/placement and interaction with other Cars on-Track to the satisfaction of INDYCAR. In general, the performance standard will be announced to all Competitors prior to the start of the first practice session. However, INDYCAR may delay announcement of the standard until a later time based on the physical condition of the Track, safety and other considerations.

## **7.10. Pit Procedures**

**7.10.1.** Cars will not be permitted to enter or exit Pit Lane from the garage area under their own power. They must be pushed or towed with a Member in the Car who is able to access the brake pedal at all times.

**7.10.2.** A Car must only use its specified Pit Box unless otherwise approved by INDYCAR.

**7.10.3.** All Cars must be centered in their assigned Pit Box. The outer point of the inside rear Tire must not exceed a maximum of four feet (48 inches) from the front face of the pit wall. The Car must be parallel to the pit wall.

**7.10.4.** For each Car, a maximum of six (6) crew members plus the Driver is permitted on the Track side of the pit wall at any one time when the Car is making a pit stop. They may assume their positions one (1) lap before the Car arrives.

**7.10.5.** Equipment and Tires on the Track side of pit wall must be attended by a crew member at all times. The outside front Tire changer must have his/her foot on the Tire until assuming position on the ground to perform pit stop duties.

**7.10.6.** Except during a pit stop, no personnel or pit equipment, including Tires, may be on the Track side of the pit wall.

**7.10.7.** An Entrant may only utilize a signboard with INDYCAR approval.

**7.10.8.** Illuminated devices used in the Pit Box during an Event must be approved by INDYCAR.

**7.10.9.** No individual shall stand on the pit wall.

**7.10.10.** Unless otherwise communicated by INDYCAR, a speed limit of 50 mph at all Road/Street Course Events and Short Oval Events and 60 mph at all Speedway Events will be enforced within the Pit Lane.

**7.10.11.** Fueling with the aid of pumps, open containers or any other device is not permitted. Only fuel from the refueling storage tank may be added to the Car.

**7.10.12.** During practice, fuel may only be added through the INDYCAR-approved dry-break disconnect system. The Engine must be shut off during any practice refueling. A crew member must operate fire equipment during any refueling.

**7.10.13.** The use of the fuel probe without flowing fuel during practice sessions is permitted.

**7.10.14.** A Driver who passes the Driver's assigned Pit Box must continue around the Track. A Car is considered to be in its assigned Pit Box if the inside rear Tire is inside the assigned Pit Box, the inside rear Tire has not crossed the centerline, and the Driver has not impeded the progress of any other Car.

**7.10.15.** A Competitor must not position a Car, equipment, and/or personnel so as to create a hazard or disruption of the Event or to interfere with the activities of another Competitor.

## **7.11. Pit Safety Violations**

**7.11.1.** Any of the following matters and any others which may be determined by INDYCAR may be cause for a Car to be penalized:

- 7.11.1.1.** Failing to follow designated procedures entering or exiting the Pit Lane, including the proper use of the acceleration and deceleration lanes, transition and through lanes, and pit exit commit lines;
- 7.11.1.2.** Attempting to leave the assigned Pit Box with air hoses, fuel hoses, tools or other equipment attached to or hanging from the Car;
- 7.11.1.3.** Car passing over or under its own air line, hose and/or any other equipment causing a safety issue and/or impeding the progress of any other Car;
- 7.11.1.4.** Car passing over or under another Car's air line, hose and/or any other equipment causing a safety issue, impacting the Car's pit stop and/or impeding the progress of any other Car;
- 7.11.1.5.** Car that makes contact with its own pit equipment while entering or exiting its Pit Box causing a safety issue and/or causing the pit equipment to leave its assigned Pit Box and/or impeding the progress of any other Car;
- 7.11.1.6.** Car that makes contact with another Car's pit equipment, causing a safety issue and/or impacting that Car's pit stop and/or impeding the progress of any Car.
- 7.11.1.7.** Contact with another Car;
- 7.11.1.8.** Contact with personnel or hitting equipment and causing it to contact personnel;
- 7.11.1.9.** Car entering a Pit Box other than the Car's assigned Pit Box.
- 7.11.1.10.** Unsafe release of a Car from its Pit Box;
- 7.11.1.11.** Pit personnel not wearing proper attire as set forth in [Rule 18.1.20](#); and
- 7.11.1.12.** More than six crew members are on the Track side of the pit wall during a Race;

**7.11.2.** Except as provided in [Rule 10.2.1](#), penalties for violations of this [Rule 7.11](#) may not be reviewed or appealed.



## 8. QUALIFICATIONS

### 8.1. All Race Locations

**8.1.1. Meeting** – INDYCAR may hold a specific meeting prior to the start of any Qualifications. INDYCAR may designate the meetings as mandatory for some Members.

**8.1.2. Starting Time** – INDYCAR shall determine the starting time for the Qualifications period.

**8.1.3. Delays** – INDYCAR may penalize any Member attempting to delay or delaying Qualifications.

**8.1.4. Interruption** – Qualifications may be interrupted by the commencement of a Yellow or Red Condition. Qualifications is suspended at the moment that the decision to interrupt is made. The decision to interrupt a Qualifications attempt or Qualifications (and reasons therefore) may not be reviewed and/or appealed.

#### 8.1.5. Technical Inspection

**8.1.5.1. Data Download** – Entrants may not download data after the checkered flag has been displayed or when directed by INDYCAR until the Car has been released from technical inspection.

**8.1.5.2. Impound Area** – Officials shall direct selected Qualified Cars to a designated “impound area” to check for compliance. A maximum of two crew members per Car will be permitted in the impound area.

**8.1.5.3. Cars** – INDYCAR reserves the right to seal any component.

**8.1.5.4. Fuel** – A fuel sample may be taken from all Cars prior to and after the Qualifications attempt.

**8.1.6. Backup Cars** – The same Car must be used in Qualifications and the Race at a Race Location unless approved by INDYCAR.

**8.1.6.1.** If a Qualified Car is involved in an incident, INDYCAR allows a Backup Car to replace the Qualified Car. The Backup Car will start the Race in the same position in the Starting Lineup as the Qualified Car.

**8.1.6.2.** If a Qualified Car is unable to start a Race for any reason other than an incident, INDYCAR decides if a Backup Car may replace the Qualified Car. If INDYCAR allows the Backup Car to replace the Qualified Car, the Backup Car will start the Race from a revised position at the rear of the Starting Lineup.

#### 8.1.7. Starting Lineup

**8.1.7.1.** INDYCAR shall determine the size and configuration of the Starting Lineup for each Race. The configuration of the Starting Lineup may include Qualified and non-Qualified Cars. The performance standard shall apply to all Cars at all times during an Event.

**8.1.7.2.** Except as otherwise provided by these Rules, the Starting Lineup shall be determined by best time rankings, from fastest to slowest, with the fastest Qualified Car occupying the Pole Position, followed by the second fastest Qualified Car, third fastest, and down through the slowest Qualified Car that has not been bumped from the Race.

**8.1.7.3.** In the event two or more Cars post identical official Qualifications times, the Cars shall be ranked in the order in which the completed Qualifications attempts occurred.

**8.1.7.4.** A Driver who has qualified a Car may not make an attempt to qualify a second Car unless the first Car has been withdrawn from the Event with permission of Officials or the first Car has been eliminated from the Starting Lineup.

**8.1.7.5.** Starting positions shall include penalties issued during Qualifications and post-Qualifications technical inspection.

**8.1.7.6.** If after the Starting Lineup has been determined, a Car has had its Qualifications time and/or original Starting Lineup position changed or disallowed, INDYCAR shall assign the Car a revised Starting Lineup position at the rear based on the following order:

- a) Cars without a Rules violation, and
- b) Cars with a Rules violation.
- c) If more than one Car is affected in either of these categories:
  - At the first Race of the Racing Season, the Cars shall be ranked using the prior year's end of season Entrant point standings. INDYCAR shall determine an Entrant's eligibility.
  - At all other Races during the Racing Season, the Cars shall be ranked using the current year's Entrant point standings entering the Race.
  - Any Car without Entrant points entering the Race will be ranked based on the Qualifications order behind all Cars with points.

#### 8.1.8. Provisional Starting Cars

**8.1.8.1.** Except at the Indianapolis 500<sup>®</sup> Mile Race, INDYCAR may offer Provisional Starting Cars at any Event if the total number of Entries for the Event exceeds the available pit space. If Provisional Starting Cars are offered, INDYCAR shall issue a bulletin detailing the Qualifications procedures and Starting Lineup prior to the first practice session.

### 8.1.9. Starting Lineup Determination

**8.1.9.1. Road/Street Course Events – Qualifications Interrupted & Not Completed –** INDYCAR shall assign all Starting Lineup positions as follows:

- a) After Segment One (1) – Should Qualifications not be completed after the completion of Segment One, the Starting Lineup will be determined as such: the Pole Position will be awarded to the best overall lap time in Segment One. The remainder of the Cars in that group will be ranked in the odd numbered positions, starting with position three (3). Even numbered starting positions will be determined from the other group, starting with position two (2).
- b) After Segment Two (2) – Should Qualifications not be completed after the completion of Segment Two, the Starting Lineup will be determined as such:
  - Segment One results shall determine position thirteen (13) through the end of the Starting Lineup.
  - Segment Two results shall determine position 1-12 to be ranked in order of time beginning with the Car posting the best-timed lap occupying the Pole Position.

Each group shall be ranked in order of best lap time as follows:

- **Group One** – occupy the odd numbered positions beginning with position thirteen (13).
- **Group Two** – occupy the even numbered positions beginning with position fourteen (14).

**8.1.9.2. All Oval Events & Road/Street Course Events – Segment One Not Completed**

- a) At the first Race of the Racing Season, the Cars shall be ranked using the prior year's end of season Entrant point standings. INDYCAR shall determine an Entrant's eligibility.
- b) At all other Races during the Racing Season, the Cars shall be ranked using the current year's Entrant point standings entering the Race.
- c) Any Car without Entrant points entering the Race will be ranked based on the Qualifications order behind all Cars with points.

### 8.2. Oval Events

**8.2.1. Rule 8.2** contains Qualifications Rules for Oval Events which are in addition to the Rules for all Race Locations contained in [Rule 8.1](#) to the extent not inconsistent with them. In the event of any inconsistency, this [Rule 8.2](#) shall supersede any other rules, as it comes to governing Oval Events.

**8.2.2. Qualifications Order –** INDYCAR shall determine the Qualifications order by Entrant points. Qualifications order will be set in reverse order of Entrant points, with the highest in points qualifying last. Entrants without points will be placed at the front of the line in an order determined by a blind draw at the first Competition meeting for that Event.

#### 8.2.3. Qualifications Line

**8.2.3.1. Cars** must be in the technical inspection line thirty (30) minutes before the beginning of Qualifications.

**8.2.3.1.1. Cars** are required to add a minimum of 3.0 gallons of fuel from the fuel depot before Qualifications as directed by INDYCAR.

**8.2.3.2. A Car** reserves its position in the Qualifications line as long as it remains in the designated position and proceeds with the Qualifications attempt when signaled. INDYCAR's decision is not subject to review and/or appeal.

**8.2.3.3. While the Car** is in the Qualifications line, an Entrant's representatives may make front/ rear wing angle, and Tire pressure adjustments only. The Car must be moved as the Qualifications line progresses. A Car must not leave the Qualifications line without the approval of INDYCAR.

#### 8.2.4. Technical Inspection

**8.2.4.1. If a Car** does not present itself for the technical inspection line at the designated start time as determined by INDYCAR, the Car shall forfeit its "Guaranteed Attempt" and may be listed at the rear of the Starting Lineup pursuant to [Rule 8.1.7.6](#). Cars experiencing an on-track Engine failure or crash may be granted a delayed entry time into the technical inspection line provided INDYCAR has granted prior approval. Car must be presented into its original spot in the Qualifications line prior to its departure time.

**8.2.4.2. When a Car** is presented for technical inspection:

- a) Fuel buckeye openings may be taped off or fitted with blanking covers; and
- b) Bodywork seams may be taped provided the tape does not change the intended shape of the part. Covering of fasteners is also permitted.

**8.2.4.3. Once a Car** has reached the entry to the technical inspection area, no external device may be connected to the Car unless approved by INDYCAR.

**8.2.4.4. Once the Car** is four (4) Cars from its Qualifications attempt, Entrant may plug in a computer and/or booster battery.

**8.2.4.5. Prior to Engine** start, all computers or any other external devices must be disconnected. Cars experiencing Engine start difficulties must have approval from INDYCAR prior to connecting any device.

**8.2.4.6. The Car** must remain as presented to the pre-Qualifications technical inspection line throughout the entire Qualifications attempt unless otherwise approved by INDYCAR.

**8.2.4.7. The PFC** pad-retraction system is the only device designed to push or pull back caliper pistons or pads that is approved for use. Pull back brakes in any other form are not permitted.

**8.2.4.8. Retracting the brake** pistons into the caliper by any method is prohibited.

**8.2.4.9.** Only after a Car's Qualifications attempt or post-Qualifications technical inspection is completed, whichever occurs later, may any of the approved aerodynamic options, approved Homologated options, or approved mechanical options be changed.

#### **8.2.5. Declaration of Intent**

**8.2.5.1.** A Car must be presented at the entrance of the "staging pit" when signaled to do so ("declaration of intent"). INDYCAR shall signal a Driver when it is time for the Car to depart from the Qualifications line to begin a Qualifications attempt. Unless otherwise provided by INDYCAR, each Car must depart the Qualifications line within sixty (60) seconds of receiving the signal.

**8.2.5.2.** In order to make an official Qualifications attempt, a Car must have been given the signal to depart from the Qualifications line and have moved away under its own power prior to the end of the Qualifications period. Notwithstanding the end of the Qualifications session, a Car may begin its Qualifications attempt, provided it has received the signal and is moving with its Engine running. The Car is not required to have completed its Qualifications attempt prior the end of the Qualifications session.

**8.2.5.3.** A Car may not be pushed to start its Engine at the start of a Qualifications attempt.

**8.2.5.4.** A Car shall be given two (2) warm-up laps. INDYCAR may add additional warm up laps, as it deems appropriate.

#### **8.2.6. Qualifications Attempt**

**8.2.6.1.** Qualifications will be based on one (1) individually timed attempt per Car. A Qualifications attempt is the total of two (2) consecutively timed laps.

**8.2.6.2.** Each Car will be permitted only one (1) departure from the Qualifications line to commence its Qualifications attempt. A Qualifications attempt may only be started and completed under the Green Condition.

**8.2.6.3.** All Cars in the Qualifications order shall be given one "Guaranteed Attempt" to qualify. Notwithstanding the foregoing, the following matters and any others as determined by INDYCAR are cause for a Car to forfeit its Guaranteed Attempt and to be listed at the rear of the Starting Lineup in accordance with [Rule 8.1.7.6](#).

- a) A Car is not presented in the proper order to the technical inspection line at the designated time, notwithstanding [Rule 8.2.4.1](#);
- b) A Car does not successfully complete technical inspection;
- c) A Car is not presented in the proper order at the staging pit;
- d) A Car fails to leave the staging pit within the designated time;
- e) A Car leaves the staging pit but fails to receive the green flag; or
- f) A Car fails to receive the checkered flag.

**8.2.6.3.1.** If more than one Car is so affected, the Cars shall be ranked according to [Rule 8.1.7.6](#).

**8.2.6.4.** If the Qualifications period concludes before each Car has been given its "Guaranteed Attempt", then Qualifications shall resume at a time designated by INDYCAR, if practicable. If INDYCAR is unable to resume Qualifications and allow each Car its Guaranteed Attempt, the entire Starting Lineup shall be determined in accordance with [Rule 8.1.9.2](#).

**8.2.6.5.** INDYCAR interrupts Qualifications attempt:

**8.2.6.5.1.** If the interruption is caused by a Car's Entrant or Driver and occurs during a Car's Guaranteed Attempt, such Car shall forfeit its Qualifications attempt and may be listed at the rear of the Starting Lineup in accordance with [Rule 8.1.7.6](#).

**8.2.6.5.2.** If the interruption is not caused by a Car's Entrant or Driver, such Car shall not be charged with a Qualifications attempt and the Car may be permitted to return to its position at the front of the existing Qualifications line and proceed with its Qualifications attempt when Qualifications resumes. The only changes that may be made to the Car are Tires may be changed, radiator shutters' opening size may be increased, and fuel added. If INDYCAR cannot resume Qualifications, INDYCAR shall preserve the Qualifications line already established. If INDYCAR releases a Car during a suspension, the Entrant is not required to keep its Car at the designated location during the suspension. Officials shall announce prior to resuming Qualifications that all Cars are to be returned to the designated location. Any Entrant not returning an Entrant's Car to the designated location by the designated time shall forfeit the Entrant's Guaranteed Attempt and may be listed at the rear of the Starting Lineup in accordance with [Rule 8.1.7.6](#).

### **8.3. Road/Street Courses**

**8.3.1.** [Rule 8.3](#) contains Qualifications Rules for Road/Street Course Events, which are in addition to the Rules for all Race Locations contained in [Rule 8.1](#) to the extent not inconsistent with them. In the event of any inconsistency, [Rule 8.3](#) shall supersede any other rules, as it comes to governing Road/Street Course Events.

**8.3.2.** Once Qualifications has begun and throughout the remainder of the Event, the aerodynamic configuration of the Car can only be changed by the addition and/or removal of approved individual parts and not by the changing of assemblies. Parts damaged during Qualifications may only be replaced by an exact matching part or assembly.

#### **8.3.3. Qualifications Groups**

**8.3.3.1.** For Segment One only, Qualifications shall be divided into two (2) groups.

**8.3.3.2.** Groups are decided by the lap times in the practice session immediately preceding Qualifications.

**8.3.3.3.** The Car with the best lap time in the practice session immediately preceding Qualifications decides groups for Segment One (1). The Entrant must notify INDYCAR of its choice via IM to the race control account within thirty (30) minutes of the completion of the practice session immediately preceding Qualifications.

**8.3.3.3.1.** If the Car with the best lap time chooses Group One (1):

**8.3.3.3.1.1.** Group One (1): Cars in the odd numbered positions, and

**8.3.3.3.1.2.** Group Two (2): Cars in the even numbered positions.

**8.3.3.3.2.** If the Car with the best lap time chooses Group Two (2):

**8.3.3.3.2.1.** Group One (1): Cars in the even numbered positions, and

**8.3.3.3.2.2.** Group Two (2): Cars in the odd numbered positions.

**8.3.3.4.** Any Cars not completing a timed lap during the practice session immediately preceding Qualifications will be ranked behind the Cars completing timed laps during the session in the order of Entrant point standings. If more than one Car has no Entrant points, the order of those Cars will be determined by random draw.

**8.3.4.** Qualifications Attempt – Qualifications will be divided into three (3) segments:

Segment One

**8.3.4.1.** All Cars shall participate in one (1) of two (2) groups for ten (10) minutes each inclusive of Red Conditions, with only the six (6) Cars posting the best lap times from each group advancing to Segment Two.

**8.3.4.2.** Segment One shall determine positions thirteen (13) through the end of the Starting Lineup. Each group shall be ranked in order of best lap time as follows:

**a)** Group one (1) occupy the odd numbered positions beginning with position thirteen (13) and;

**b)** Group two (2) occupy the even numbered positions beginning with position fourteen (14).

**8.3.4.3.** Group two (2) shall begin five (5) minutes after the conclusion of Group one (1) or as determined by INDYCAR.

Segment Two

**8.3.4.4.** Segment Two (2) shall consist of one ten (10) minute Qualifications group inclusive of Red Conditions, with all times from Segment One (1) having been voided. Only the six (6) Cars posting the best lap times shall advance to Segment Three (3). Segment Two (2) shall begin ten (10) minutes after the conclusion of Segment One (1) as determined by INDYCAR.

**8.3.4.5.** Segment Two (2) shall determine positions seven (7) – twelve (12) to be ranked in order of time beginning with the Car posting the seventh best-timed lap occupying the seventh (7th) position.

Segment Three

**8.3.4.6.** Segment Three (3) shall consist of six (6) minutes of guaranteed Green Condition time, with all times from Segment Two (2) having been voided. In the event of a Red Condition, session timing will stop.

**8.3.4.6.1.** Segment Three (3) shall begin ten (10) minutes after the conclusion of Segment Two (2) as determined by INDYCAR.

**8.3.4.7.** Segment Three (3) shall determine positions one (1) – six (6) to be ranked in order of best lap time beginning with the Car posting the best-timed lap occupying the Pole Position.

**8.3.5.** If a Car causes a Red Condition in any segment, the Car's best two (2) timed laps of the segment shall be disallowed, the Car may not continue in the segment, and the Car shall not advance to the next segment.

**8.3.6.** If a Car interferes with the Qualifications attempt of another Car other than through a Red Condition:

**8.3.6.1.** If the violation occurs during Segment One (1) or Segment Two (2), the Car's best two (2) timed laps during that segment shall be disallowed and the Car shall not advance to the next segment.

**8.3.6.2.** If the violation occurs during Segment Three (3), all Segment Three (3) times shall be voided and the Car shall not be permitted to participate in the remainder of Qualifications.

**8.3.6.3.** A Car not improving its previous section times in any portion of the Track may be cause for interference with another Car.

**8.3.6.4.** If a Car causes a Yellow Condition that requires another Car to comply with [Rule 7.1.3.2](#), the Car's best-timed lap to that point during that Qualifications segment shall be disallowed, regardless of whether the other Car complied with [Rule 7.1.3.2](#). If the Car does not have a timed lap recorded when causing the Yellow Condition, a Black Flag drive-through penalty will be assessed once the lap on which the Yellow Condition occurred has been completed.

**8.3.7.** The Pole Position Car will start from the inside of the front row.

**8.3.8.** Attempt Not Completed

**8.3.8.1.** If one or more Cars does not post a time within its respective group or segment, such Cars will be ranked at the rear of its respective group or segment based upon:

**8.3.8.1.1.** Segment One (1): Qualifications order

**8.3.8.1.2.** Segment Two (2): Segment One (1) lap times

**8.3.8.1.3.** Segment Three (3): Segment Two (2) lap times

### 8.3.9. Segment Extensions

**8.3.9.1.** If a Green Condition occurs prior to the completion of any segment, INDYCAR may delay the display of the Checkered Flag to allow each Car leaving Pit Lane enough time for one (1) timed lap. Each Car must leave its Pit Box within thirty (30) seconds of the Green Condition.

**8.3.9.2.** If Segment One (1) and/or Segment Two (2) concludes without enough Cars posting a time to fill the advancing positions, INDYCAR may restart the session to allow each Car leaving Pit Lane enough time for one (1) timed lap. Each Car must leave its Pit Box within thirty (30) seconds of the Green Condition.

**8.3.10.** Double-Header Race Qualifications – Rule 8.3.10 contains Qualifications Rules for Double-Header Race Qualifications, which are in addition to the Rules for all Race Locations and Road/Street Course Events contained in Rule 8.1 and Rules 8.3 respectively to the extent not inconsistent with them. In the event of any inconsistency, Rule 8.3.10 shall govern Double-Header Race Qualifications

**8.3.10.1.** Each Race Qualifications is one (1) session with two (2) groups.

#### 8.3.10.2. Race One (1) Groups

- Cars are divided into one (1) of two (2) groups.
- Groups are decided by the lap times in the practice session immediately preceding Race One (1) Qualifications.
- The Car with the best lap time in the practice session immediately preceding Race One (1) Qualifications decides groups for Race One (1) Qualifications. The Entrant must notify INDYCAR of its choice via IM to the race control account within thirty (30) minutes of the completion of the practice session immediately preceding Race One (1) Qualifications.
- If the Car with the best lap time chooses Group One (1):
- Group One (1): Cars in the odd numbered positions, and
- Group Two (2): Cars in the even numbered positions.
- If the Car with the best lap time chooses Group Two (2):
- Group One (1): Cars in the even numbered positions, and
- Group Two (2): Cars in the odd numbered positions.
- The order is:
- Group one (1), and
- Group two (2).

#### 8.3.10.3. Race Two (2) Groups

- The same groups as Race One (1) Qualifications are used for Race Two (2) Qualifications.
- The order is:
- Group two (2), and
- Group one (1).

#### 8.3.10.4. Race One (1) and Race Two (2) Attempts

**8.3.10.4.1.** Each group has twelve (12) minutes of Track time, including five (5) minutes of guaranteed Green Condition time.

**8.3.10.4.2.** The Car with the best overall lap time earns the Pole Position.

**8.3.10.4.3.** The remaining Cars in the Pole Position Car's group will be ranked by best lap time in each session in the odd numbered positions, starting with position three (3). The remaining Cars in the other group will be ranked by best lap time in each session in the even numbered positions, starting with position two (2).

#### 8.3.10.5. Attempt Not Completed

**8.3.10.5.1.** If one or more Cars does not post a time within its respective group, such Cars will be ranked at the rear of its respective group based upon Qualifications order.

#### 8.3.10.6. Race One (1) and Race Two (2) Alternate Procedures – Session Not Completed

**8.3.10.6.1.** All Cars will be ranked by Entrant point standings entering each Race.

**8.3.10.6.2.** Any Car without Entrant points entering the Race will be ranked based on the Qualifications order behind all Cars with points.

**8.3.10.6.3.** Points are not earned.

## 8.4. Indianapolis 500® Mile Race

### TO BE ISSUED VIA BULLETIN

## 9. PENALTIES

### 9.1. General

**9.1.1.** INDYCAR may penalize any Member for any violation of the Rules. If an Official observes or is made aware of an act or omission by a Member that constitutes a violation of the Rules, the Official shall promptly report the violation to INDYCAR. INDYCAR shall consider the report and shall conduct whatever additional inquiry it deems appropriate under the circumstances. After concluding the inquiry, INDYCAR shall determine whether disciplinary action is appropriate and if so, what disciplinary action should be taken. The Member shall be informed of the determination and if disciplinary action is imposed, INDYCAR shall issue a penalty notice to the Member specifying the violation, a brief statement of the circumstances of the violation and the penalty imposed. If the act or omission of a Member is determined by INDYCAR to constitute a threat to the integrity or safety of INDYCAR, the NTT IndyCar Series or to the orderly conduct of an Event or to constitute a violation during an Event, INDYCAR may take immediate action against the Member.

**9.1.2.** The Race Stewards shall monitor violations of the Sporting Regulations of the Rules during Qualifications and/or Races. The Race Stewards and/or the Race Director may request a Steward's Review at any time. Each Race Steward votes for or against the issuance of a penalty, a majority vote determines if a penalty is issued, and the individual votes are not released or made public. Once this determination is made, the Race Stewards shall determine the severity of the penalty from the Penalty Guidelines developed by INDYCAR based on majority vote. A Race Steward will notify the Race Director who shall advise the Competitors and broadcast/media of the determination and/or penalty either: (i) "Car #\_\_\_ was under Steward's Review and no further action is required" or (ii) "Quoting Rule #\_\_\_ and Car #\_\_\_, the penalty is issued."

### 9.2. Scope of Penalties

**9.2.1.** Penalties for violations of the Rules are divided into two categories: Race Procedure penalties and non-Race Procedure penalties. Penalties are determined by the gravity of the violation and its impact on the fairness of competition, the orderly conduct of the Event and the interests and integrity of automobile racing, INDYCAR and the NTT IndyCar Series. INDYCAR shall have the authority to impose any or all or any combination of the following penalties against any Member for any violations of the Rules at any time.

**9.2.2.** Race Procedure Penalties – Violation of Race Procedures generally result in penalties imposed during on-Track activity. If circumstances do not permit a penalty to be served during on-Track activity, INDYCAR shall declare the results provisional and subject to examination which shall take no longer than one (1) hour after the displaying of the checkered flag. This examination is independent of the Competitor's requirement to pass post-Race technical inspection. If the imposition of a penalty is near or at the end of the on-Track activity and the Driver/Car does not fulfill it, INDYCAR may reposition the Driver/Car in the posting of results. Additional penalties may be applied to subsequent on-Track activities to reflect the fulfillment of the penalty. Except as provided in Rule 10.2.1, the penalty, including without limitation any repositioning in a posting, is non-reviewable and/or appealable.

**9.2.2.1.** Black Flag – INDYCAR may impose black flag penalties.

**9.2.2.2.** Laps – INDYCAR may impose lap penalties. Lap penalties shall be imposed in complete laps only. The imposition of a lap penalty shall result in the removal of official credit for the specified number of penalty laps from the total laps credited to the Competitor and the scoring records and all points and awards shall reflect the removal of penalty laps.

**9.2.2.2.1.** If the lap penalty is imposed during the on-Track activity, the removal of official credit shall begin with the Competitor's lap in which the violation occurred and shall include subsequent consecutive laps, as determined by INDYCAR.

**9.2.2.2.2.** If the lap penalty is imposed after the on-Track activity is completed, INDYCAR shall determine, based on the severity of the violation, whether the removal of official credit shall begin with the Competitor's last lap and include previous consecutive laps as required, or begin with the Competitor's lap in which the violation occurred.

**9.2.2.2.3.** INDYCAR shall make a reasonable effort to notify the penalized Competitor of a lap penalty at the time it is determined. However, failure to notify the Competitor during the on-Track activity will in no way mitigate or change the penalty.

**9.2.2.3.** Time – INDYCAR may impose time penalties as described below. The imposition of a time penalty may result in the removal or addition of the specified amount of time to the Competitor and the timing and scoring records and awards shall reflect the removal or addition of time.

**9.2.2.3.1.** If the time penalty is imposed during a subsequent on-Track activity, the time shall be removed from the Entrant's Open Test or Team Test, practice session and/or Qualifications period. The time penalty must be fulfilled when directed by INDYCAR. The time penalty begins when the Member, the Member's Car and Entrant personnel are in Pit Lane.

**9.2.2.3.2.** If the time penalty is imposed during the current on-Track activity, time shall be removed or added to the Entrant's overall time on the official posting.

**9.2.2.4.** On-Track Repositioning – INDYCAR may impose a repositioning penalty during on-Track activities. The repositioning penalty will result in an order change of the Car's on-Track position.

**9.2.2.5.** Starting Lineup Repositioning – INDYCAR may impose a Starting Lineup penalty. A Starting Lineup penalty is repositioning of an Entrant in the Starting Lineup. If a Starting Lineup repositioning penalty is announced, the recipient of the repositioning penalty may not pit until a Green Condition occurs, unless approved by INDYCAR.

**9.2.2.6.** Disqualification – INDYCAR may disqualify the Member. Disqualification shall entail the loss of any right to compete in the remainder of the current Event from the time at which the disqualifying condition first occurred. It may entail the forfeiture of Entry fees paid or payable and INDYCAR shall determine, based on the severity of the violation, whether or not the disqualification includes the forfeiture of points and awards earned up to the moment at which time the infraction for the disqualification first occurs.

**9.2.3.** Non-Race Procedure Penalties – Violations of non-Race Procedures generally result in penalties imposed during off-Track activity. Penalties are reviewable and/or appealable except as provided in Rule 10.2.1.

- 9.2.3.1. Additional Appearances and/or Meetings** – INDYCAR may require a Member to attend and actively participate in appearances and/or meetings in addition to those required of the Member, other Members, pursuant to the Rules and any other agreements. INDYCAR may specify the due date for completion. Failure to attend and/or participate by the due date may result in reinstatement of the monetary fine if a monetary fine was imposed, or additional penalties as determined by INDYCAR.
- 9.2.3.2. Monetary Fines** – INDYCAR may issue monetary fines and specify the due date for payment. Unpaid fines may be deducted from any awards payable by INDYCAR to the Entrant or Manufacturer associated with such Member. INDYCAR may suspend or refuse to approve the renewal of the License and/or membership of any Member failing to timely pay any fine during the period the fine remains unpaid.
- 9.2.3.3. Probation** – INDYCAR may place a Member on probation. Probation is a state of limitation upon a Member's privileges. During probation, a Member is under heightened scrutiny and the Member can be required to abide by specified standards of conduct that are more stringent than those which are otherwise applicable to Members under the Rules. If a Member violates probation, the Member is subject to a more severe penalty as determined by INDYCAR. INDYCAR shall determine the duration and conditions of probation.
- 9.2.3.4. Suspension** – INDYCAR may suspend a Member. A suspension may be total suspension from INDYCAR or it may be limited to a suspension of membership or License privileges at a Race Location facility or facilities, or for a particular Event or Events, or for a specified or indefinite period of time. Unless expressly limited, a suspension shall entail the loss of any right to take part in any capacity whatsoever in any Event or Events included in the suspension. Unless otherwise stated, individuals under suspension will not be issued credentials of any kind for an Event and the privileges and uses of the Track, pit area, garage area and other restricted areas will be denied. Every suspended individual shall return all credentials and/or Licenses to INDYCAR who will not return them until the term of the suspension has expired. Any delay in surrendering the credentials and/or Licenses may be added to the term of the suspension. If the suspended individual does not return the credentials and/or Licenses, the credentials and/or Licenses shall be inoperative and invalid until the lifting of the suspension and the Member may be subject to additional penalty for failure to return the credentials and/or Licenses. Suspension may also render void any previous Entry made for any Event occurring during the term of such suspension and may entail the forfeiture of any applicable Entry fees paid or payable for any such Entries. INDYCAR shall have the right to reduce, increase, or otherwise modify the unexpired term of a suspension issued under the Rules.
- 9.2.3.5. Loss of Points and/or Awards** – INDYCAR may rule that a Member who violates the Rules will forfeit all or a portion of the points and/or awards earned in that year, including points and awards earned in the Event in which the violation occurred.

### **9.3. Additional Provisions and Guidelines**

- 9.3.1. Improper Conduct** – Any Member attempting to or engaging in unsportsmanlike conduct, unsafe conduct, or conduct detrimental to racing; INDYCAR; and/or to the NTT IndyCar Series, whether during an Event or on/off the Track, may be subject to any or all penalties. Improper conduct shall include, without limitation:
  - 9.3.1.1.** Engaging in reckless, careless, unsafe, and/or overly aggressive actions, or unsportsmanlike behavior;
  - 9.3.1.2.** Impeding the conduct of an Event, including Car control, placement and inconsistent driving pattern;
  - 9.3.1.3.** Causing an avoidable Yellow or Red Condition;
  - 9.3.1.4.** Endangering the safety of Members, or others;
  - 9.3.1.5.** Failing to participate at competitive speed;
  - 9.3.1.6.** Failing to interact with other Cars on-Track to the satisfaction of INDYCAR;
  - 9.3.1.7.** Failing to follow the direction of INDYCAR; and/or
  - 9.3.1.8.** Using improper, profane, or disparaging language or gestures in reference to any Official, Members or anyone else or improper, profane or disparaging language or gestures in reference to, concerning or connected in any way with INDYCAR, the NTT IndyCar Series, or any Event and could result in additional penalties as determined by INDYCAR.
- 9.3.2. Blocking** – A Driver must not alter his/her racing line to pursuing Drivers.
- 9.3.3. Avoidable Contact** – The primary responsibility for avoiding contact with a Competitor resides with the overtaking Competitor and the secondary responsibility resides with the Competitor(s) being overtaken. A Competitor who fails to demonstrate their responsibility and initiates a maneuver that results in contact with another Competitor may be penalized.
  - 9.3.3.1. Driver Involved in Multiple Contact** – Any Driver determined to be in violation of [Rule 9.3.3.](#) (avoidable contact) two (2) times during any three (3) consecutive Race Events shall be placed on probation for a period of the Drivers next five (5) Race Events.
- 9.3.4. Team Tactics and/or Team Orders** – Team tactics and/or Team orders are actions or omissions by one or more Members to artificially influence, affect, alter, and/or otherwise interfere with the normal course of an on-Track Event. Team tactics and/or Team orders are not permitted. If INDYCAR determines one or more Members attempted to or engaged in Team tactics and/or Team orders, INDYCAR may issue a penalty to any or all of the Members, including without limitation any or all of a Team's Car/Driver combinations.
- 9.3.5. Assault or Battery** – If any Member shall attempt to or commit an assault or battery, such Member may be disqualified and/or suspended by INDYCAR and may be subject to additional penalties.

**9.3.6. Gambling on Events** – Applicants and Members shall not engage, nor attempt to engage, in any gambling activity (as defined below) relating to any Event, or any portion of an Event, (i) in which INDYCAR is involved, including, but not limited to, NTT IndyCar Series, Indy Lights, Indy Pro 2000 Championship, USF2000 National Championship and/or MX-5 Cup events, or (ii) that in the judgment of INDYCAR could represent and represents the potential for a conflict of interest, unsportsmanlike conduct or conduct detrimental to racing and/or INDYCAR Group. This Rule applies to all gambling activities including without limitation, those available in any gaming facility, casino, lottery gaming facility, racetrack gaming facility, or on the internet or electronically, or in all other establishments and locations. Gambling activity, for purposes of the above, is defined as placing anything of value at risk, whether monetary or otherwise, in connection with a bet, wager, or game of chance. If an applicant or Member wishes to participate in any gambling activity associated with or related to INDYCAR or its affiliates (for example, a celebrity blackjack tournament), he/she may do so only if he/she has received the prior written authorization of INDYCAR. Such authorization, if granted, will be limited to the extent authorized by INDYCAR.

**9.3.7. Social Media** – Competitors and Officials must comply with provisions of the INDYCAR Social Media Policy at all times.

**9.3.8. Detrimental Member Conduct** – The favorable reputation of INDYCAR, and its Members, is a valuable asset and creates tangible benefits to all involved. Accordingly, it is an obligation of all Members to refrain from engaging in conduct which is detrimental to INDYCAR and its Members. Such conduct shall include, but not be limited to comments to the news media that unreasonably attack or disparage Members or INDYCAR. Responsible expressions of legitimate disagreement with INDYCAR are not prohibited. However, public comments a Member knows, or should reasonably know, will harm the reputation or financial best interests of a Member or INDYCAR are expressly covered by this Rule.



## 10. REVIEW

### 10.1. Introduction

**10.1.1.** Except as expressly provided in these Rules, the exercise of judgment by Officials during an Event issuing a penalty or otherwise shall not be reviewed and the decision of Officials is final and binding. By submitting a membership application and in consideration of receiving the numerous benefits available, each Member agrees that the final and binding decisions of Officials are non-litigable. No court action of any kind may be taken by any Member. Further, there is no right of review or appeal of any INDYCAR decision or penalty to FIA and/or ACCUS-FIA and/or any other third party including the FIA International Court of Appeals and ACCUS-FIA National Court of Appeals, even if an Event is listed by ACCUS-FIA and/or another ASN on the FIA international calendar. By reason of membership in INDYCAR and/or participation in an Event, any Member waives any rights such Member may otherwise have to be a party or to take any action in court seeking legal or equitable relief against any decision or action of any kind by INDYCAR, the Officials, anyone acting on behalf of INDYCAR, the review facilitator and/or the appeal panel. Each Member acknowledges that participation in an Event by other Members is in part in reliance on this waiver. If a Member initiates or participates in litigation in violation of these Rules, all membership privileges may thereupon be suspended, and Member is subject to the provisions of Rule 1.4 of these Rules.

### 10.2. When is a Review Permitted

**10.2.1.** Race Procedure penalties are not subject to review and appeal, except for (i) disqualification, (ii) suspension, (iii) probation, (iv) a monetary fine in excess of Ten Thousand and 00/100 Dollars (\$10,000.00), (v) an award fine, and/or (vi) a point fine.

**10.2.2.** Non-Race Procedure penalties are subject to review and appeal, provided a review is permitted by the Rules and the request for review is in accordance with these Rules.

**10.2.3.** An applicant or Member may not request review of the existence or wording of a Rule and/or the non-imposition of a penalty.

### 10.3. Who May Request a Review

**10.3.1.** Only the Entrant submitting an Entry may request a review of the rejection of the Entry. Any Competitor who competes in any Event that is not in accordance with the published Entry form conditions waives the right to challenge the non-enforcement of such conditions.

**10.3.2.** Only the individual or entity submitting a license or membership application may request a review of a decision related to such application.

**10.3.3.** Only the Member receiving a penalty may request a review of the penalty of the Member.

**10.3.4.** If more than one Member is involved in the same violation of these Rules, each Member must submit a request for review.

### 10.4. Process to Request a Review

**10.4.1.** A request for review shall be in writing and include the following:

- a) Clearly state the errors claimed;
- b) Each claimed error must be stated in specific terms and must be accompanied by a written statement of the facts and grounds upon which it is based.
- c) Designate a single point of contact for the party requesting the review and contain the name, address, e-mail and telephone number for this person who will be the only point of contact concerning the review with respect to such party.

**10.4.2.** The request for review must be delivered to and received by INDYCAR within two (2) Business Days of issuance of the penalty or decision (not including the day the penalty or decision is issued) and sent via email to:

[Rules@indycar.com](mailto:Rules@indycar.com)

**10.4.3.** A request for review shall be considered received only upon INDYCAR's actual receipt of the request and INDYCAR's email response to the sender confirming INDYCAR's receipt. INDYCAR is not responsible for errors in electronic transmission and/or receipt of the request.

**10.4.4.** If INDYCAR decides a request for review does not adhere to these Rules, it may be dismissed and treated as if it were not submitted. If the two (2) Business Days have passed, a new request for review may not be submitted. If the two (2) Business Days have not passed, a new request for review may be submitted.

**10.4.5.** If INDYCAR decides a request for review adheres to these Rules, INDYCAR specifies an individual to serve as review administrator to assist the review party, INDYCAR and the review facilitator with any and all administrative aspects of the review. The review administrator is not involved in any substantive manner in the review. During the review process, the review administrator is the only point of contact for the review party, INDYCAR, and the review facilitator regarding the administrative aspects of the review process.

## 10.5. Review Process

**10.5.1.** The review will be conducted by a review facilitator. The review will be heard by one (1) of the following possible review facilitators:

Kevin Miller	Bill Bock	John Darby
Bill Baten	Robin Pemberton	Gary Roberts
Vicki O'Connor	Frank Pulice	Rollie Helmling
Billy Boat	Dan Cotter	John Schneider
Chris Paulsen	Buddy Rice	Lyn St. James

**10.5.1.1.** Upon receipt of a request for review, the review administrator will notify each individual in the pool of the receipt of a request for review to confirm availability and identify any potential or actual conflicts of interest. The notice may include the general timing for a review, the names of the affected applicants or Member(s), and a brief description of the penalty or decision.

**10.5.1.2.** Within three (3) Business Days of INDYCAR's receipt of a request for review, INDYCAR shall provide in writing to the party requesting the review the names of three (3) review facilitators from the above list. INDYCAR shall determine the three (3) review facilitators based upon the type of penalty (e.g., technical regulation, sporting regulation); the particular specialization or expertise, availability and conflicts of interest of the review facilitators; and such other factors as may indicate the overall ability of the review facilitator to assist in the review.

**10.5.1.3.** Within one (1) Business Day of the party's receipt of the three (3) review facilitators from INDYCAR, the party requesting the review shall provide the name of one (1) review facilitator via email to the review administrator. In the event there are multiple parties submitting a review for the same violation of these Rules, the party submitting the first request for review actually received by INDYCAR shall select the review facilitator for and on behalf of such party and all other parties requesting a review.

**10.5.1.4.** Within one (1) Business Day of INDYCAR's receipt of the one (1) review facilitator from the party requesting the review, INDYCAR shall provide in writing to the party requesting the review confirmation of the status of the review facilitator.

**10.5.1.4.1.** If INDYCAR confirms the review facilitator is available, INDYCAR shall decide upon an acceptable date for the review meeting.

**10.5.1.4.2.** If INDYCAR confirms it was unable to contact the review facilitator or INDYCAR contacted the review facilitator, but the review facilitator was unavailable or had a conflict of interest, the party requesting the review shall provide in writing to INDYCAR the name of an alternate one (1) review facilitator from the same list of three (3) facilitators initially provided within one (1) Business Day of receipt of INDYCAR's confirmation. If each of the three (3) individuals could not be contacted, were unavailable and/or had conflicts of interest, the review administrator will notify the party submitting the review in writing of INDYCAR's three (3) alternate individuals in the pool. This process shall continue until such time as a review facilitator has been selected.

**10.5.2.** Once the review facilitator has been selected, the review administrator provides the review facilitator with the Rules and all applicable bulletins to date. Once the review facilitator has entered into the confidentiality agreement, the review administrator provides the review facilitator with non-public information and documents concerning the review.

**10.5.3.** The review facilitator must decide if the request for review adhered to the Rules.

**10.5.4.** If the review facilitator decides the request for review did not adhere to the Rules, the request for review may be dismissed, disregarded as having never been submitted, and the review facilitator may disallow any new submission of the same issue for review.

**10.5.5.** If the review facilitator decides the request for review adhered to these Rules, the review meeting will be conducted within ten (10) Business Days of the issuance of the penalty with the review meeting date during the time period to be determined by INDYCAR.

**10.5.6.** The review meeting will be conducted by a review facilitator at the INDYCAR offices located in Indianapolis, Indiana. If the parties and the review facilitator mutually agree, they may decide upon a location other than the INDYCAR offices in Indianapolis, Indiana and/or another location than Indianapolis, Indiana.

**10.5.7.** The review will take place in the form of a meeting conducted by the review facilitator. The review meeting will be either an in-person meeting or via telephone or video conference. In the event the parties and review facilitator cannot agree on whether the meeting will be in-person, via telephone or via video conference, the review shall be an in-person meeting. The review meeting will not proceed for more than a single day and will not be more than four (4) hours during this day, unless agreed to by the review facilitator and all parties.

**10.5.8.** The review meeting is not open to the public and admittance is limited to INDYCAR, the party/parties requesting the review and its/their representative(s), and the review facilitator. INDYCAR and the party/parties requesting the review may not appear at the review meeting through or accompanied by legal counsel. Within two (2) Business Days prior to the review meeting, INDYCAR and each party seeking a review shall provide the review facilitator with: i) the names, titles and contact information of all attendees to the review meeting and the purpose for which each will be present at the review meeting, and ii) a summary of its position not to exceed five (5) double spaced pages in length, not including supporting documentation. The total number of attendees at the review meeting is limited to three (3) per party. INDYCAR and each party requesting the review shall have at least one (1) attendee with full authority to reach a resolution of the penalty at the review meeting. The review facilitator does not exchange position summaries with the other parties and/or INDYCAR unless the parties and INDYCAR mutually agree.

**10.5.9.** The review meeting is limited to the issues raised in the written request(s) for review.

**10.5.10.** Except as otherwise provided in Rule 1.1.3.3, the review and all discussions, information and documents concerning the review and at the review meeting are confidential. The party/parties requesting the review and all present at the review meeting or in possession or control of such documents and information shall enter into a confidentiality agreement supplied by INDYCAR prior to the commencement of the review meeting. The review facilitator shall enter into the confidentiality agreement prior to receiving any information and documents concerning the review. Any party that does not timely enter into the confidentiality agreement provided by INDYCAR will not be permitted to participate in the review meeting and such party will no longer have a right to have the penalty reviewed and appealed.

**10.5.11.** Consistent with the informal and collaborative nature of the review meeting, there shall be no transcript or recording of the meeting and the review facilitator will determine the format. The review facilitator shall decide the number of sessions, whether they are joint or separate, and who will participate in each session, consistent with an opportunity for each participant to present their position and facilitate the resolution of the issue(s) presented.

**10.5.12.** At the conclusion of the review meeting:

The review facilitator shall provide her/his thoughts concerning the penalty and whether the penalty should be upheld, overturned or modified and, if modified, provide a recommended modification. Any decision or recommendation by the review facilitator as part of the review process is not binding upon INDYCAR or the party/parties requesting the review and is confidential and subject to the confidentiality agreement set forth in this Rule 10.

The review facilitator shall allocate the reasonable costs and expenses of the review facilitator amongst INDYCAR and each party submitting a review of the penalty. INDYCAR and each party submitting a review shall bear their own fees, costs and expenses.

**10.5.13.** During the review meeting and through the conclusion of the appeal process, if applicable, the review facilitator shall not be employed by or on behalf of or otherwise affiliated in any other capacity with INDYCAR and/or any of the parties to the review and/or appeal; however, the review facilitator may continue to serve in his/her capacity as a review facilitator and/or appeal panel member for other requests for review and/or appeal.

**10.5.14.** During the review process, the review facilitator must strive to uphold the integrity of INDYCAR, the NTT IndyCar Series, and the Events. At all times, the review facilitator must be professional, courteous, and independent.

**10.5.14.1.** The review facilitator has a duty to disclose any potential or actual conflicts of interest that may exist or arise with regards to any of the review participants.

**10.5.14.2.** Any appearance of impropriety will not be allowed and may result in removal of a review facilitator from a review and/or from the list of possible review facilitators in these Rules.

**10.5.14.3.** The review facilitator should refer any media inquiries to the review administrator.

**10.5.14.4.** The review facilitator must thoroughly review the submissions and familiarize himself/herself with the issues during the review; however, the review facilitator must not perform any independent review or research and/or communicate in any manner about the subject matter of the review by or amount any of the review participants outside of the review process. The review facilitator is expected to vigorously apply the Rules to the facts in order to reach a thorough, thoughtful, and fair decision.

**10.5.15.** After the conclusion of the review meeting, the review facilitator shall destroy any and all notes, records and/or other electronic and hard copy documents received regarding the review.

**10.5.16.** Within two (2) Business Days of the review meeting, INDYCAR and each party submitting review shall pay the review facilitator their respective share of the review facilitator costs and expenses.

## **10.6. Compliance with Procedures**

**10.6.1.** Any request for review that fails to comply with any of the foregoing requirements will be dismissed with prejudice and disregarded as having never been submitted. Any error not specifically raised in the request for review is waived.

## 11. APPEALS

### 11.1. Introduction

Except as expressly provided in these Rules, the exercise of judgment by Officials during an Event issuing a penalty or otherwise shall not be appealed and the decision of Officials is final and binding. By submitting a membership application and in consideration of receiving the numerous benefits available, each Member agrees that the final and binding decisions of Officials are non-litigable. Each Member agrees to abide by the decision of the appeal panel. No court action of any kind may be taken by any Member. Further, there is no right of review or appeal of any INDYCAR decision or penalty to FIA and/or ACCUS-FIA and/or any other third party including the FIA International Court of Appeals and ACCUS-FIA National Court of Appeals, even if an Event is listed by ACCUS-FIA and/or another ASN on the FIA international calendar. By reason of membership in INDYCAR and/or participation in an Event, any Member waives any rights such Member may otherwise have to be a party or to take any action in court seeking legal or equitable relief against any decision or action of any kind by INDYCAR, the Officials, anyone acting on behalf of INDYCAR, the review facilitator and/or the appeal panel. Each Member acknowledges that participation in an Event by other Members is in part in reliance on this waiver. If a Member initiates or participates in litigation in violation of these Rules, all membership privileges may thereupon be suspended and is subject to the provisions of [Rule 1.4](#) of these Rules.

### 11.2. When is an Appeal Allowed

Only penalties satisfying the following requirements may be appealed: penalties subject to review under [Rule 10](#) of these Rules, penalties that have completed the review process under [Rule 10](#) of these Rules, and penalties that are the subject of a request for appeal in compliance with this [Rule 11](#). An applicant or Member may not request appeal of the existence or wording of a Rule and/or the non-imposition of a penalty.

### 11.3. Who May Request an Appeal

Only the party/parties satisfying the following requirements may appeal a penalty: party/parties that originally submitted the penalty for review under [Rule 10](#) of these Rules, and parties that have participated in the review process under [Rule 10](#) of these Rules, including entering into the confidentiality agreement.

### 11.4. Submission of Appeals

**11.4.1.** If an appeal is permitted under these Rules, an appeal shall be in writing and include the following:

- a) Clearly state the errors claimed.
- b) Each claimed error must be stated in specific rather than general terms and must be accompanied by a written statement of the facts and grounds upon which it is based.
- c) Designate a single point of contact for the party submitting the appeal and contain the name, address, e-mail and telephone number for this person who will be the only point of contact concerning the appeal with respect to such party.

**11.4.2.** The request for appeal must be delivered to and received by INDYCAR within three (3) Business Days after the conclusion of the review meeting set forth in [Rule 10](#) of these Rules (not including the day of the review meeting) and sent via email to:

[Rules@indycar.com](mailto:Rules@indycar.com)

**11.4.3.** A request for appeal shall be considered received only upon INDYCAR's actual receipt of the request and INDYCAR's email response to the sender confirming INDYCAR's receipt. INDYCAR is not responsible for errors in electronic transmission and/or receipt of the request.

**11.4.4.** If INDYCAR decides a request for appeal does not adhere to these Rules, it may be dismissed and treated as if it were not submitted. If the three (3) Business Days have passed, a new request for appeal may not be submitted. If the three (3) Business Days have not passed, a new request for appeal may be submitted.

**11.4.5.** If INDYCAR decides a request for appeal adheres to these Rules, INDYCAR specifies an individual to serve as appeal administrator to assist the appeal party, INDYCAR and the appeal panel chair with any and all administrative aspects of the review. The appeal administrator is not involved in any substantive manner in the appeal. During the appeal process, the appeal administrator is the only point of contact for the appeal party, INDYCAR, and the appeal panel chair regarding the administrative aspects of the appeal process.

### 11.5. Appeal Process and Hearing

**11.5.1.** An appeal is intended to be formal, as compared to the informal review process.

**11.5.2.** Except as otherwise provided in [Rule 1.1.3.3](#), the appeal and all discussions, information and documents concerning the appeal and at the appeal hearing are confidential. The party/parties submitting the appeal and all present at the appeal hearing or in possession or control of such documents and information shall enter into a confidentiality agreement supplied by INDYCAR prior to the commencement of the appeal hearing. Each member of the appeal panel shall enter into the confidentiality agreement prior to receiving any information and documents concerning the appeal. Any party that does not timely enter into the confidentiality agreement provided by INDYCAR will not be permitted to participate in the appeal and such party will no longer have a right to an appeal of the penalty.

**11.5.3.** There shall be no transcript or recording of the appeal hearing.

**11.5.4.** The appeal must contain reference to the specific action by Officials from which an appeal is taken, the date of the occurrence, the reasons for the appeal, and the relief requested. The appeal must be accompanied by copies of all written documents pertaining to the appeal, such as the written review request submitted under Rule 10 of these Rules, responses, rulings and declarations. The appeal must clearly and explicitly state the basis of the appeal.

**11.5.5.** The appeal will be conducted by an appeal panel. To participate in a particular appeal, the panel member must be available and without potential or actual conflicts of interest. The appeal will be heard by an appeal panel comprised of three (3) of the panel members listed below. In the event there are multiple parties submitting an appeal for the same penalty, the party submitting the first appeal actually received by INDYCAR shall choose the appeal panel for and on behalf of such party and all other parties requesting an appeal.

Kevin Miller	Bill Bock	John Darby
Bill Baten	Robin Pemberton	Gary Roberts
Vicki O'Connor	Frank Pulice	Rollie Helmling
Billy Boat	Dan Cotter	John Schneider
Chris Paulsen	Buddy Rice	Lyn St. James

**11.5.6.** Upon receipt of a request for appeal, the appeal administrator will notify each individual in the pool of the receipt of a request for appeal to confirm availability and identify any potential or actual conflicts of interest.

**11.5.7.** Within three (3) Business Days after receiving a written appeal, the appeal administrator shall conduct a conference call with INDYCAR and the person designated as the only point of contact for the party filing an appeal, to choose the three (3) members of the appeal panel. During this conference call, INDYCAR and appeal party shall be ready and have full authority to choose the three (3) member appeal panel. The appeal administrator shall inform INDYCAR and the appeal party of any individuals in the pool with confirmed unavailability and/or with potential or actual conflicts of interest, and those individuals may not be selected for the appeal panel. The appeal party shall choose the first appeal panel member. Next, INDYCAR shall choose an appeal panel member. The third member of the appeal panel will be chosen by agreement of INDYCAR and the appeal party. If INDYCAR and the appeal party cannot agree on the third appeal panel member, three (3) potential appeal panel members will be randomly chosen by INDYCAR from the remaining potential appeal panel members in Rule 11.5.5 above. The appeal party shall strike one potential appeal panel member from this list, then INDYCAR shall strike one potential appeal panel member from this list, and the individual remaining is the third member of the appeal panel and the chair of the appeal panel. The chair of the appeal panel is responsible for coordinating with the other appeal panel members and being the only contact among the appeal panel and INDYCAR and the appeal party/parties regarding all aspects of the appeal and appeal hearing.

**11.5.8.** Once the three (3) member appeal panel is chosen, the appeal panel shall govern the appeal process and conduct an appeal in-person hearing. Any direction, decision, determination or act by the appeal panel shall be made by a majority vote of the three (3) members of the appeal panel.

**11.5.9.** During and through the conclusion of the appeal process, the appeal panel members shall not be employed by or on behalf of or otherwise affiliated in any other capacity with any of the parties to the review and/or appeal; however, the appeal panel members may serve in his/her capacity as a review facilitator and/or appeal panel member for other requests for review and/or appeal.

**11.5.10.** During the appeal process, the appeal panel must strive to uphold the integrity of INDYCAR, the NTT IndyCar Series, and the Events. At all times, the appeal panel must be professional, courteous, and independent.

**11.5.10.1.** The appeal panel has a duty to disclose any potential or actual conflicts of interest that may exist or arise with regards to any of the appeal participants.

**11.5.10.2.** Any appearance of impropriety will not be allowed and may result in removal of an appeal panel member from an appeal and/or from the list of possible appeal panel members in these Rules.

**11.5.10.3.** The appeal panel members should refer any media inquiries to the appeal administrator.

**11.5.10.4.** Each member of the appeal panel must thoroughly review the submissions and familiarize himself/herself with the issues during the appeal; however, the appeal panel must not perform any independent review or research and/or communicate in any manner about the subject matter of the appeal by or amount any of the appeal participants outside of the formal appeal structure. The appeal panel members are expected to vigorously apply the Rules to the facts in order to reach a thorough, thoughtful, and fair decision.

**11.5.11.** Once the appeal panel has been selected, the appeal administrator provides the appeal panel chair with the Rules and all applicable bulletins to date. Once each appeal panel member has entered into the confidentiality agreement, the appeal administrator provides the appeal panel chair with non-public information and documents concerning the appeal.

**11.5.12.** The appeal panel must decide if the request for appeal adheres to these Rules.

**11.5.13.** If the appeal panel decides the request for appeal did not adhere to these Rules, the request for appeal may be dismissed, disregarded as having never been submitted, and the appeal panel may disallow any new submission of the same issue. The appeal panel must still issue a confidential written decision to the appeal party and INDYCAR.

**11.5.14.** If the appeal panel decides the request for appeal adhered to these Rules, the appeal hearing shall be concluded within seven (7) Business Days of the submission of the appeal. If the parties and the appeal panel are unable to decide upon an acceptable date during the seven (7) Business Day period, the appeal panel shall decide upon a date within three (3) Business Days after such seven (7) Business Day period (e.g. appeal panel could choose the 8<sup>th</sup> – 10<sup>th</sup> Business Day) and such decision is final and binding on the parties.

**11.5.15.** The appeal panel shall establish the timing and process for each party to submit a written statement concerning the appeal and any supporting documentation; the exact time of the appeal hearing; the duration of the appeal hearing; and who may attend the appeal hearing. INDYCAR and the party/parties requesting the appeal shall be permitted to appear at the appeal hearing through or accompanied by legal counsel. Notwithstanding the foregoing, the timing and process shall include the following components at a minimum:

**11.5.15.1.** Within two (2) Business Days prior to the appeal hearing, INDYCAR and each party seeking an appeal shall provide the appeal panel with:

- a)** The names, titles and contact information of all attendees to attend the appeal hearing and the purpose for which each present at will be the appeal hearing, and
- b)** a summary of its position not to exceed ten (10), double spaced pages in length, not including supporting documentation.

The appeal panel does not exchange position summaries with the other parties and/or INDYCAR unless the parties and INDYCAR mutually agree.

**11.5.15.2.** The appeal panel shall conduct the hearing in the following manner. Prior to opening statements or the submission of proof by the party requesting the appeal, the appeal panel may request that INDYCAR submit an explanation of the basis of its decision.

**11.5.15.2.1.** Opening Statements – The parties to the proceedings will be permitted to make opening statements, with the party requesting the appeal making the first opening statement. Each party shall state the issue(s) before the appeal panel and a brief summary of the position of the party with respect to such issue(s).

**11.5.15.2.2.** Order of Proof – The evidence shall be received by the appeal panel in the following order:

**11.5.15.2.2.1.** The party requesting the appeal shall first submit and present evidence in support of the appeal. Upon the completion of direct examination, each witness shall be subject to cross-examination by the other parties and by the appeal panel.

**11.5.15.2.2.2.** INDYCAR and the other parties shall then be permitted to present evidence, and any witnesses presented shall be subject to cross-examination by the party requesting the appeal, by other parties, and by the appeal panel.

**11.5.15.2.2.3.** Closing Arguments – Upon completion of the evidentiary portion of the hearing, all parties, beginning with the party requesting the appeal, may make closing arguments.

**11.5.16.** The appeal hearing will be conducted at the INDYCAR offices located in Indianapolis, Indiana. If the parties and the appeal panel mutually agree, they may decide upon a location other than the INDYCAR offices in Indianapolis, Indiana and/or another location than Indianapolis, Indiana.

**11.5.17.** The appeal hearing is not open to the public and admittance to the hearing is by invitation of the appeal panel and can be revoked. The appeal panel shall identify the parties and other necessary participants in the proceedings. Each party is permitted a maximum of three (3) attendees at the appeal hearing, including legal counsel, but not including any Members or other witnesses appearing at the request of the appeal panel. INDYCAR and each party requesting the appeal shall have at least one (1) attendee with full authority at the appeal hearing. The appeal panel may summon any Member to testify at the hearing. If a Member is called as a witness and fails to appear, INDYCAR may revoke the Member's License and/or membership and/or otherwise penalize the Member.

**11.5.18.** The hearing shall be confined to the errors claimed in the appeal and evidence relevant to those errors.

**11.5.19.** The appeal panel shall not be limited to the technical common law rules of evidence required in judicial proceedings but shall be satisfied the evidence submitted is of a type on which the appeal panel can rely. The appeal panel may exclude irrelevant, immaterial, or unduly repetitious evidence.

**11.5.20.** All parties to the proceedings shall be permitted to present and cross-examine witnesses and to submit evidence, both oral and documentary. The burden of proof shall remain at all times on the party/parties submitting the appeal.

**11.5.21.** The decision of the appeal panel is final and binding on INDYCAR and each party submitting an appeal. An appeal panel decision may not include the re-drafting of a Rule and/or a Penalty Guideline. The appeal panel shall issue a confidential written determination of the appeal within three (3) Business Days of the conclusion of the appeal hearing and this written determination is subject to the confidentiality agreement set forth in this [Rule 11](#). After the conclusion of the appeal hearing, the appeal panel shall destroy any and all notes, records, and/or other electronic and hard copy documents received regarding the appeal.

**11.5.22.** The appeal panel shall allocate the reasonable costs and expenses of the appeal panel amongst INDYCAR and each party submitting an appeal of the penalty. INDYCAR and each party submitting an appeal shall bear their own attorneys' fees, costs and expenses. Within ten (10) Business Days from the appeal panel's decision, INDYCAR and each party submitting an appeal shall pay the appeal panel their respective share of the remaining appeal panel costs and expenses.

## **11.6. Compliance with Procedures**

**11.6.1.** Any appeal that fails to comply with any of the foregoing requirements will be dismissed with prejudice and disregarded as having never been submitted. Any error not specifically raised in the appeal shall be deemed to have been waived.

## 12. CHAMPIONSHIP AND POINTS

### 12.1. Championships and Point Standings

**12.1.1.** INDYCAR recognizes several different types of championships, including, without limitation, Engine Manufacturer, Entrant and Driver. To facilitate competition for these championships, INDYCAR calculates and publicizes complete rankings of all participating Engine Manufacturers, Entrants and Drivers following the completion of each Race and Indianapolis 500<sup>®</sup> Mile Race Qualifications. Unless otherwise announced by INDYCAR, all scheduled Qualifications and Races shall offer championship points.

**12.1.2.** At the end of the Racing Season, the Engine Manufacturer, Entrant and Driver with the highest number of ranking points respectively shall be declared the Champion.

### 12.2. Significance of the Car Number

**12.2.1.** Points and awards are credited only to the Engine Manufacturer supplying the Engine, Entrant entered in the Event and to the Driver participating in that Car except as otherwise permitted by INDYCAR. The Car number is listed on the Entry and signifies the Car to be credited. The points and awards accumulate on behalf of the entered Car number, separately from any other Entrant's License that Team may hold.

### 12.3. Crediting of Points

**12.3.1.** INDYCAR has established the following system under which eligible Engine Manufacturers, Entrants and Drivers may accumulate points.

**12.3.2.** Entrant points will be credited only to an Entrant holding a valid Entrant's License at the time of the Event, competing with a properly entered Car and displaying the assigned Car number throughout any Event.

**12.3.3.** Driver points will be credited only to Drivers holding a valid Driver License at the time of the Event.

**12.3.4.** INDYCAR will not credit the point(s) usually earned by the Entrant and Driver starting a Race in the Pole Position if the Starting Lineup is determined in accordance with Rule 8.1.9.2.

**12.3.5.** If a Car participates in practice and/or Qualifications, but is unable to start a Race, the Driver and/or the Entrant shall receive half of the points the Car would have received for the Race had the Car started the Race ("non-starting Cars"). INDYCAR shall determine whether a Car is deemed to have participated for purposes of this Rule.

**12.3.6.** Unless otherwise provided by INDYCAR, all Entries shall be eligible for Entrant and Driver points associated with participation in an Event.

### 12.4. Ties

**12.4.1.** In any instance of a tie, INDYCAR will determine the ranking based on the following criteria:

- a) The most first place finishes,
- b) The most second place finishes through last place finishes,
- c) The best finishing position in the previous Event, or
- d) Random draw.

### 12.5. End of Season Awards

**12.5.1.** INDYCAR reserves the right to establish end of season awards based upon points.

### 12.6. Points

**12.6.1.** Points may be earned by Entrants, Drivers and Engine Manufacturers based upon participation in Races and Qualifications.

**12.6.2.** Entrant/Driver Race Points – INDYCAR will award points pursuant to finishing position as follows:

	Position	Points	Position	Points	Position	Points
Race Finish Points	1	50	12	18	23	7
	2	40	13	17	24	6
	3	35	14	16	25	5
	4	32	15	15	26	5
	5	30	16	14	27	5
	6	28	17	13	28	5
	7	26	18	12	29	5
	8	24	19	11	30	5
	9	22	20	10	31	5
	10	20	21	9	32	5
	11	19	22	8	33	5
Leading At Least One Lap: 1 Point						
Most Laps Led: 2 Points						

**12.6.2.1. Double Points** – Double race finish points are awarded for the Indianapolis 500<sup>®</sup> Mile Race and the last Race of the Racing Season.

	Position	Points	Position	Points	Position	Points
<b>Race Finish Double Points</b>	1	100	12	36	23	14
	2	80	13	34	24	12
	3	70	14	32	25	10
	4	64	15	30	26	10
	5	60	16	28	27	10
	6	56	17	26	28	10
	7	52	18	24	29	10
	8	48	19	22	30	10
	9	44	20	20	31	10
	10	40	21	18	32	10
	11	38	22	16	33	10
Leading At Least One Lap: 1 Point						
Most Laps Led: 2 Points						

**12.6.3. Entrant/Driver Qualifications Points**

**12.6.3.1. Double-Header Race Events** – Points are awarded as follows:

Race 1 – 1 point to the Entrant and Driver with the fastest time in each Qualifications Group.

Race 2 – 1 point to the Entrant and Driver with the fastest time in each Qualifications Group.

**12.6.3.2. All Other Events** – Except as otherwise provided in Rule 12.6.3.1, INDYCAR shall award one point to the Entrant and Driver qualifying for the Pole Position.

**12.6.4. Indianapolis 500<sup>®</sup> Mile Qualification Points**

	Position	Points
<b>Indy 500 Qualifying Pts</b>	1	9
	2	8
	3	7
	4	6
	5	5
	6	4
	7	3
	8	2
	9	1

**12.6.5. Engine Manufacturer Championship Points** - Race finish points are awarded on a Race-by-Race basis and may only be scored by the top two (2) finishing Full Season Entrant positions by each assigned Engine Manufacturer, added throughout the Racing Season based upon the following system.

	Position	Points	Position	Points	Position	Points
<b>Engine Manufacturer Points</b>	1	50	12	18	23	7
	2	40	13	17	24	6
	3	35	14	16	25	5
	4	32	15	15	26	5
	5	30	16	14	27	5
	6	28	17	13	28	5
	7	26	18	12	29	5
	8	24	19	11	30	5
	9	22	20	10	31	5
	10	20	21	9	32	5
	11	19	22	8	33	5

**12.6.5.1. Additional points available as follows:**

**12.6.5.1.1.** One (1) point will be awarded for an Engine Manufacturer that qualifies in the Pole Position, with the exception of Indianapolis 500<sup>®</sup> Mile Race Qualifications.

**12.6.5.1.2.** For the Indianapolis 500<sup>®</sup> Mile Race Qualifications, one (1) point will be awarded to the Engine Manufacturer of the fastest qualifier of Saturday Qualifications and two (2) points will be awarded to the Engine Manufacturer that qualifies in the Pole Position on Sunday Qualifications.

**12.6.5.1.3.** The Engine Manufacturer that wins each Race will be awarded five (5) points.



**12.6.5.1.4.** An Engine Manufacturer can earn durability points during the Indianapolis 500<sup>®</sup> Mile Race based upon performance by Entrants that are using such Engine Manufacturer's Engine. As an Engine used in the Indianapolis 500<sup>®</sup> Mile Race reaches 2,000 total Engine miles or more, that Entrant's Engine Manufacturer will receive a one-time bonus points award equal to the Race finish points earned by that Entrant for the Indianapolis 500<sup>®</sup> Mile Race.

**12.6.5.1.5.** Engine Manufacturers will only be awarded Qualifications and Race win bonus points for Engine Manufacturer-points-eligible Entrants. These points awards are not subject to reordering due to points ineligibility.

## 13. COMMERCIAL ACTIVITIES & AWARDS

### 13.1. Logo Display

13.1.1. All Members agree to comply with the INDYCAR Style Guide, including, without limitation, display of all required emblems on all uniforms, Cars and other equipment and/or use of all required equipment. The INDYCAR Style Guide can be accessed at [epaddock.indycar.com](http://epaddock.indycar.com).

### 13.2. Advertising

13.2.1. INDYCAR may regulate or deny the advertising of any product on equipment, apparel or otherwise in connection with a Member, INDYCAR, the NTT IndyCar Series or any Event.

13.2.2. Advertising may not be displayed until it has been approved by INDYCAR. INDYCAR may disapprove advertising for any reason, including, without limitation, advertising which it determines is offensive, inappropriate, illegal, undignified, in conflict with any INDYCAR or Event Promoter sponsorship, potentially confusing or may detract from the interest in any Event and/or the integrity of INDYCAR and/or the NTT IndyCar Series.

13.2.3. INDYCAR may require a Member to agree in writing with a policy statement regarding advertising of a particular product.

13.2.4. Product advertising must comply with all Rules, including without limitation, size.

### 13.3. Title Sponsor

13.3.1. No Member shall grant any sponsorship or other promotional rights to any party for any products or services in the Title Sponsor Category (as defined below) unless approved in writing by the Title Sponsor. If any Member grants sponsorship or other promotional rights to any party that offer products and/or services in the Title Sponsor Category or are otherwise competitive with products and/or services offered by the Title Sponsor, such party shall activate its rights only with respect to its other separate business lines which are not in the Title Sponsor Category and not with respect to the Title Sponsor Category.

13.3.1.1. For purposes of this Rule 13.3, Title Sponsor Category is defined as IT services and solutions which includes the following:

13.3.1.1.1. Application Services – full scope of end-to-end application capabilities for both custom and enterprise applications, including app development, modernization, testing, management and outsourcing.

13.3.1.1.2. Business Process Outsourcing – managing non-core business processes with industry specific platforms, robotic process automation, and straight-through processing to improve productivity.

13.3.1.1.3. Cloud Services –on-demand access to resources, via the internet, using servers or hybrid solutions.

13.3.1.1.4. Consulting Services – strategic business and IT consulting, managed security consulting and technical consulting that helps clients devise a strategy, build a roadmap and implement processes and systems that support long-term business advantage.

13.3.1.1.5. Data Center Services – deploying operational management, network services, disaster recovery with consulting, design, installation, consolidation, and relocation to reduce process cycle times and improve productivity.

13.3.1.1.6. Digital Business Services –enable new business models by leveraging technologies including analytics, mobile, customer engagement, block chain, cloud and the internet of things.

13.3.1.1.7. Dynamic Workplace Services – end-user outsourcing with workplace virtualization, custom apps, unified communications, field services, collaboration, managed mobility, and end-user analytics.

13.3.1.1.8. Network Services—connectivity solutions using centralized control and configured policies to route traffic along the most suitable connection. This capability boosts application performance and improves connectivity to cloud-based resources.

13.3.1.1.9. Security Services—services that secure your business across the entire information and communications technology stack and throughout the full security life cycle and limit and remove business disruption and data loss.

13.3.1.1.10. Competitors in the IT Services and Solutions category include, but are not limited, to the following (in alphabetical order): Accenture; Amazon; Atos; Automatic Data Processing; Capgemini; CGI; Cognizant; Deloitte; DXC; EY; Fujitsu; HCL Technologies; Hitachi; IBM; Infosys; KPMG International; Leidos; PwC; Tata Consultancy Services and Wipro.

13.3.2. Notwithstanding Rule 13.3.1, no Member shall be required to breach any existing agreement in effect as of January 15, 2019 and may continue to fulfill its obligations to such parties in accordance with the terms of such agreements, including any renewal rights contained in those agreements subject to the limitation that any such renewal shall not increase a Title Sponsor Competitor's third party's prominence in the Title Sponsor Category (i.e. visibility or sponsorship rights) with respect to the Member within the NTT IndyCar Series.

### 13.4. Product Use

13.4.1. A Member shall not make a false or potentially false public or private statement concerning any product used or said to have been used in any Event. An Entrant may be required to provide INDYCAR with an affidavit certifying product use. Display of an emblem on a Car or uniform does not constitute a statement concerning use.

**13.4.2.** INDYCAR may certify that a product was used at any Event(s). To be eligible to receive certification of product use, the product manufacturer must agree in writing to the following:

**13.4.2.1.** The product manufacturer must agree in writing to be bound by the Rules and must agree to be subject to penalty pursuant to the Rules.

**13.4.2.2.** Product manufacturers posting awards contingent on product use and the display of advertising during an Event must provide INDYCAR with a statement of the conditions at least 30 days prior to the Event. The product manufacturer shall provide INDYCAR with proof of award distribution in accordance with these conditions within 30 days of certification by INDYCAR of the product use.

**13.4.2.3.** Any advertisement of products and the related use of these products during an Event must be consistent with the facts as determined by INDYCAR and must not be likely to deceive, or mislead, the public.

**13.4.2.4.** INDYCAR may add or revoke requirements, as it deems appropriate.

## **13.5. Media**

### **13.5.1. Testing**

**13.5.1.1.** Members agree to provide a minimum of one (1) hour of media availability per on-Track Test Day.

### **13.5.2. Pre-Race Activities**

**13.5.2.1.** Driver Autograph Sessions – INDYCAR may conduct one or more autograph sessions of Drivers during each Event.

**13.5.2.2.** Practice – Requested Drivers must attend post-practice media appearance.

**13.5.2.3.** Qualifications – Drivers must attend the following:

- Pole Qualifications media “bullpen” appearance.
- Pole winner photograph obligations.

Immediately following Qualifications, media center appearance:

- Oval Events: the Drivers starting in the first row and any other requested Drivers.
- Road Course/Street Course Events: the top six (6) Drivers.

**13.5.2.4.** Pre-Race Ceremonies – Unless otherwise directed, the Drivers shall proceed to the Pre-Race stage and fully participate in Pre-Race ceremonies including without limitation any Driver introductions and/or Track laps.

**13.5.3.** Post-Race Activities – Unless otherwise directed, the top three finishers in the Race shall proceed to victory lane as instructed by INDYCAR and fully participate in post-Race ceremonies including without limitation, not removing, obscuring, or otherwise altering any sponsor recognition. Specifically, at a minimum, this includes the following:

**13.5.3.1.** The winning Driver must attend and participate in post-Race interviews in victory lane. The winning Driver and Car Owner of a Race agree to permit the display on the Car in victory lane, as designated by INDYCAR, at least one item from the Title Sponsor and one item from the Car’s sponsor as determined by INDYCAR, including size, location and placement of such item(s). The winning Driver and Entrant agrees to participate in a photograph session with the Event sponsor(s) and guests.

**13.5.3.2.** The 2<sup>nd</sup> through 5<sup>th</sup> place Drivers must stop in Pit Lane or such other area as designated by INDYCAR and participate in media interviews.

**13.5.3.3.** The 2<sup>nd</sup> and 3<sup>rd</sup> place Drivers must proceed to victory lane and join the Race winner in post-Race ceremonies. The top three finishers must wear INDYCAR provided hats in the following order: Firestone, NTT IndyCar Series and Engine Manufacturer.

**13.5.3.4.** Immediately following victory lane ceremonies, the winning Driver, 2<sup>nd</sup> place Driver and 3<sup>rd</sup> place Driver must attend and participate in post-Race interviews in the media center.

**13.5.3.5.** Following the media center interviews, the winning Driver shall attend and participate in a satellite media tour and radio media tour, if requested by INDYCAR. At Races designated by INDYCAR, the Race winner shall stay overnight for a victory media tour the following Day.

**13.5.3.6.** All other Drivers agree to attend and participate in the post-Race media center interview process, if requested by INDYCAR.

**13.5.4.** Indianapolis 500<sup>®</sup> Mile Race – All Drivers in the Starting Lineup must attend and actively participate in media events, at such times and locations as designated by INDYCAR, for a media day/photograph and video shoot, with travel provided by INDYCAR. The winning Driver must take the traditional drink of milk in victory lane. The winning Driver and Car owner must attend and participate in the victory banquet at such times and locations as designated by INDYCAR. The winning Driver agrees to attend and participate in a national media tour that may include a trip or trips to national media markets.

**13.5.4.1.** Indianapolis 500<sup>®</sup> Mile Race: If Entrant wins the Indianapolis 500<sup>®</sup> Mile Race, it agrees to grant to the Event Promoter or its designee, through execution of a separate agreement, the right to possess and use the winning Car for display during mutually agreed upon times. Consideration for the above use of the winning car is acknowledged as the opportunity to compete for awards for the on-Track Event and acceptance of the Entry.

**13.5.5.** Championship – All Drivers and Entrants mathematically eligible to win the end of season Driver and/or Entrant point standings agree to attend and participate in activities as follows:

**13.5.5.1.** Race market for final Race: a media activity approximately four weeks prior to the end of season Event.

- 13.5.5.2.** During the final five (5) Races: designated pre-Race and/or post-Race media requirements, including national media teleconferences, press conferences, satellite media tours and/or radio tours as directed by INDYCAR.
  - 13.5.5.3.** Championship Event(s) during Event week: media event(s) as designated by INDYCAR.
  - 13.5.5.4.** NTT IndyCar Series Champion: a national media tour that could include a trip or trips to national media markets, if requested by INDYCAR.
  - 13.5.5.5.** Celebration – The winning Driver and Car owner must attend and participate in the celebration at such times and locations as designated by INDYCAR.
  - 13.5.5.6.** Championship: If Entrant wins the championship, it agrees to grant to INDYCAR or its designee the right to possess and use the winning Car for display during mutually agreed upon times of the celebration. Consideration for the above use of the winning Car is acknowledged as the opportunity to compete for awards for the on-Track Events and acceptance of the Entries
- 13.5.6.** Penalties – INDYCAR shall determine whether a Member has failed to attend, failed to actively participate, or engaged in inappropriate conduct during a meeting or mandatory activity. The following penalties may apply:
- 13.5.6.1.** First Offense – \$5,000 and/or require attendance at an additional/substitute meeting and/or promotional appearances.
  - 13.5.6.2.** Each Additional Violation – INDYCAR may double the fine, require attendance at additional/substitute meetings or activities.
  - 13.5.6.3.** Whether in attendance or not, Members shall be charged with knowledge of the matters discussed at all meetings (whether mandatory or not). A Member and the Member's Entrant waive the right to review and/or appeal any penalties that may be assessed for any violation of the Rules if the Member was absent, did not actively participate, or engaged in inappropriate conduct at the meeting.
  - 13.5.6.4.** Cellular telephones or wireless mobile devices may only be used for the purpose of taking notes during any meeting and/or activity unless approved by INDYCAR.

### **13.6. Awards**

- 13.6.1.** Entrants and Drivers displaying the mandatory award sponsors and otherwise complying with the Rules may be eligible to earn awards.
- 13.6.2.** The distribution of all awards must be approved by INDYCAR.
- 13.6.3.** INDYCAR shall determine the eligibility, nature and amount of all awards for:
  - a)** Each Event, and
  - b)** End of season.
- 13.6.4.** Withholding
  - 13.6.4.1.** Offset – INDYCAR shall have the right to offset any amounts owed by a Member to INDYCAR, an Event Promoter or a Manufacturer against any award otherwise payable to the Member or the Member's Entrant. If INDYCAR receives notice that Member has failed to pay an Event Promoter or Manufacturer, INDYCAR shall have the right to pay the Event Promoter or Manufacturer directly after giving the Member a 48 (forty-eight) hour period to dispute the offset. Should the Member dispute the offset or in the event INDYCAR receives conflicting demands for such amounts, INDYCAR shall, at its option, be entitled to seek a court order to ascertain the rightful distribution of funds.
  - 13.6.4.2.** All awards may be withheld by INDYCAR in whole or in part, or denied in whole or in part, if INDYCAR determines in its discretion that any member of Entrant Group has failed in any way to comply with the terms and conditions of the Rules.
- 13.6.5.** Review – If a review is requested in accordance with Rule 10, affecting the distribution of an award, all awards so affected shall be forwarded to the INDYCAR office or in the case of monetary awards placed in an escrow account as directed by INDYCAR within five Business Days after the filing of the review, without obligation as to interest.

## 14. TECHNICAL SPECIFICATIONS

### 14.1. General

- 14.1.1. INDYCAR shall maintain a technical site on (IRIS) for Members to submit questions and INDYCAR to provide technical information or provide various technical updates when necessary.
- 14.1.2. Questions to be submitted and will be answered via IRIS. Modifications must be approved seven (7) days prior to the date of intended use.
- 14.1.3. All parts provided by an Approved Supplier must be used as supplied without modification unless otherwise approved by INDYCAR and stated in these Rules or in update bulletins.
- 14.1.4. Approved Suppliers must submit bulletins to INDYCAR for approval prior to releasing bulletins to Entrants. Once submitted bulletins are approved by INDYCAR, Members are subject to enforcement by INDYCAR.
- 14.1.5. All original Manufacturer identification markings and/or tags must remain as supplied.
- 14.1.6. Tape is not permitted as a single source of attachment for any component.
- 14.1.7. The drink bottle, if utilized, must be installed in one (1) of the following locations: on the top side of the underwing, under the structural front sidepod, or on the structural front sidepod.
  - 14.1.7.1. For all Events excluding the Indianapolis 500<sup>®</sup>, the drink bottle and accessories may be installed at all times.
  - 14.1.7.2. The drink bottle may not have any content until the Race.
  - 14.1.7.3. For the Indianapolis 500<sup>®</sup> race, the drink bottle and accessories may not be installed until Carburetion Day.
- 14.1.8. Entrants must utilize mufflers (Supertrapp 443-2010 4") in garage area when engines are started.
  - 14.1.8.1. At Events where garage structures are utilized, Entrants must roll Cars out from under roof when Engines are started.
- 14.1.9. Anodizing of parts is permitted.

### 14.2. Development Areas, Reproduction Parts, and Direct Purchase Parts

#### 14.2.1. Development Areas

- 14.2.1.1. The following areas are open for development. The mating part(s) must remain as supplied, and the areas must otherwise comply with the Rules.
  - 14.2.1.1.1. Non-Engine oil and greases,
  - 14.2.1.1.2. Dampers and inerters ([Rule 14.10](#)),
  - 14.2.1.1.3. Treatments and coatings of the inside of the gearbox and/or gearbox internals,
  - 14.2.1.1.4. Treatments and coatings of all bearing surfaces.
  - 14.2.1.1.5. Bearings and bearing races (excluding upright and gearbox bearings) provided they are of the same size, type and design as originally provided by the Approved Supplier.
    - 14.2.1.1.5.1. Hybrid and/or ceramic bearings are not approved for use.
  - 14.2.1.1.6. Fuel cell collector pot (the fuel cell collector pot must remain inside the fuel cell, must have a [-6-port plug drain-valve](#) at the base of the collector, and must fill during an INDYCAR performed fuel cell capacity check),
  - 14.2.1.1.7. Refueling hose end that connects to the tank,
  - 14.2.1.1.8. Internal brake ducting must be completely contained within the brake duct.
  - 14.2.1.1.9. Brake bias cable (concept of operation must remain the same as the supplied bias cable)
  - 14.2.1.1.10. Bushings,
  - 14.2.1.1.11. Plumbing,
    - 14.2.1.1.11.1. Water pipes,
    - 14.2.1.1.11.2. Oil pipe (at least a six (6) inch flexible section must remain at the radiator end of the pipe),
    - 14.2.1.1.11.3. Plumbing of the fuel cell lines,
    - 14.2.1.1.11.4. All other plumbing is limited to a change of line type, size, fittings, and routing.
  - 14.2.1.1.12. Spacers,
  - 14.2.1.1.13. Drive peg extensions,
  - 14.2.1.1.14. Pushrod ends,
  - 14.2.1.1.15. Anti-rotational devices are permitted on pushrods and toelinks, provided they remain parallel to the mounting surface. Devices must be submitted to INDYCAR via IRIS for approval.
  - 14.2.1.1.16. Anti-roll bar adjusters must be submitted to INDYCAR via IRIS for approval

- 14.2.1.1.17. Nuts and bolts including bolt head types.
- 14.2.1.1.18. Heat shielding other than fabrics or sleeving must be submitted to INDYCAR via IRIS for approval.
- 14.2.1.1.19. Pedal heads must be submitted to INDYCAR via IRIS for approval,
- 14.2.1.1.20. [Speedway front wing adjuster knob.](#)
- 14.2.1.1.21. [Brake master cylinder rod extensions](#)
- 14.2.1.1.22. [Throttle damper extension](#)
- 14.2.1.1.23. [Brake pedal pivot bushing](#)
- 14.2.1.1.24. Seals – except for those listed in [Rule 14.16.3.](#)
- 14.2.1.1.25. Studs – except for those listed below:

	Commercial Part Number	Application
Studs Purchased From Dallara	IR1204A019	Front Wing Mainplane Stud SW
	IR1204B039	Front Wing Mainplane Stud RC
	IR1207B016	Caliper Stud M10
	IR1208A005	Rear Rocker Main Stud
	IR1208A014	Suspension Clevis Stud w / Shoulder
	IR1208A015	Suspension Clevis Stud w/o Shoulder
	IR1221A001	Lower Engine Stud, Honda Installation
	IR1221A002	Upper Engine Stud, Honda Installation
	IR1221B003	Bellhousing to Gearbox Stud 7/16
	IR1221B009	Bellhousing to Gearbox Stud 7/16
	IR1222A001	Lower Engine Stud, Chevy Installation
	IR1222A002	RH Upper Engine Stud, Chevy Installation
	IR1222A003	LH Upper Engine Stud, Chevy Installation

#### 14.2.2. Reproduction Parts

14.2.2.1. The parts listed below may be reproduced or purchased directly from Dallara. The parts must be consistent with the approved drawings including material. Any variations from the approved drawings must be submitted to INDYCAR via IRIS for approval. Specific details and drawings related to each part are available on the INDYCAR ePaddock ([Approved Development Drawings](#)).

14.2.2.1.1. Air jack receptacle (the air jack receptacle must remain in the INDYCAR-approved location)

14.2.2.1.2. Pedal stems,

14.2.2.1.3. Pedal brackets,

14.2.2.1.4. Wheel nut socket conical guide,

14.2.2.1.5. Rear shock shear plates,

14.2.2.1.6. Rockers,

14.2.2.1.7. Anti-Roll Bar drop links,

14.2.2.1.8. Anti-roll bar blades, and

14.2.2.1.9. Anti-roll bars.

14.2.2.2. The parts listed below may be reproduced or purchased directly from Approved Suppliers. The reproduced part must be consistent with the original approved part including material. Any variations from the approved part must be submitted to INDYCAR via IRIS for approval.

14.2.2.2.1. Refueling hose-to-probe connectors:

- Rapid Prototyping & Engineering, Inc. (Part #INDYCAR 0512), or
- Checkered Past Machine (Part #CPIC060).

### 14.2.3. Direct Purchase Parts

14.2.3.1. Entrants may purchase the following parts directly from the INDYCAR Approved Supplier:

14.2.3.1.1. Water radiators:

- PWR Water Radiator CR-UGMPR047C
- PWR Water Radiator PWR78165
- PWR Water Radiator 19010-FC8ZA-111M2
- Mezzo Water Radiator 1549-1000
- Mezzo Water Radiator 19010-FC8ZA-021M1
- Mezzo Water Radiator 1549-8000

14.2.3.1.2. Oil radiators:

- PWR Engine/Gearbox Oil Cooler CR-UC-MQC003B

14.2.3.1.3. PFC Brakes:

- Discs 328.30.0044.24
- Disc bells front 218.779.128.15 and rear 218.779.307.15
- Pads 7990.0002.24.01
- Calipers 90.328.365.01/02
- Disc mounting hardware and bobbins per INDYCAR-approved PFC Order Form (available at [ePaddock.com](http://ePaddock.com) - [PFC Order Form](#)).

14.2.3.1.4. Premier fuel cell bladder part # 1200-0518 IRL125014 4 Fuel Bladder.

### 14.3. Technical Inspection

14.3.1. INDYCAR decides the factors in inspection, and it may vary by Entrant, portion of Event and/or Event.

14.3.1.1. INDYCAR decides the order of inspection.

14.3.1.2. Entrants are required to have the tools necessary to fulfill work as requested by INDYCAR.

14.3.1.3. A penalty may still be issued, even if the Car or part completed inspection at an earlier Event and/or earlier portion of the same Event.

14.3.2. The responsibility remains with the Entrants to make sure Cars conform to all Rules throughout the course of an Event.

14.3.3. Reference planes and '0' coordinates

14.3.3.1. All measurements shall be taken from the reference plane or '0' coordinates. These shall be established by Dallara and cannot be modified.

14.3.3.2. References will be measured using the following coordinates:

- a) "X" coordinate is defined as the relative location fore and aft of the front face of the forward chassis bulkhead - "0" being the forward face of the chassis. These measurements will be referred to as +/- the "X" line, with - (negative) being forward.
- b) "Y" coordinate is defined as the location laterally from the chassis centerline, Driver's right-hand side being positive.
- c) "Z" coordinate is defined as the location vertically with the bottom of the skid being 0 'Z', + (positive) being up.

The bottom of the skid establishes the "chassis reference plane." For purposes of technical inspection, the "chassis reference plane" is 1.000 inches above the plane established using "Tech Tool Monocoque Nosepin Machined Plate, IR1201977" and the gearbox reference puck as defined in "Xtrac Technical Bulletin 020" and "Dallara Technical Bulletin IR15 13.01 (2015).

14.3.4. The engine and gearbox installed angle is minus 0.10 degrees to 0.10 degrees relative to the '0' line.

14.3.5. INDYCAR may inspect, impound and/or confiscate any Car, part, equipment, item, or data associated with a Car or its operation during an Event at any time. INDYCAR is not responsible for damage or loss as a result of inspection procedures, impounding, or confiscation.

14.3.5.1. Entrants must submit to INDYCAR via IRIS (under the Technical Data section) a complete Cosworth dataset from the outing that contains the fastest lap after practice session one (1), Qualifications, and the final practice session, within one (1) hour after completion of the session. INDYCAR may request additional datasets.

14.3.6. The maximum amount of fuel allowed in the Car when coming through Entrant-initiated technical inspection is six (6) gallons. The Car must be empty of fuel when being weighed.

## 14.4. Car Weight and Driver Equivalency Weight

### 14.4.1. Car Weight

14.4.1.1. The minimum weight shall include the car in ready-to-compete condition, excluding Driver, Driver Equivalency Weight, fuel and drink bottle content.

14.4.1.1.1. Minimum weight for Road/Streets Events – will be ~~1625-1630~~ pounds.

14.4.1.1.2. Minimum weight for Speedway Events – will be 1590 pounds.

14.4.1.1.3. Minimum weight for Short Oval Events – will be 1620 pounds.

14.4.1.2. The only approved ballast location is the keel.

### 14.4.2. Driver Equivalency Weight

14.4.2.1. INDYCAR specifies the Driver Equivalency Weight. INDYCAR shall notify each Entrant of its Driver Equivalency Weight.

14.4.2.2. Driver Equivalency Weight must bring the combined weight of the Driver and Driver ballast to 185 pounds.

14.4.2.3. INDYCAR may weigh any Driver and adjust the Driver ballast accordingly.

14.4.2.4. Drivers over 185 pounds are allowed a Car weight reduction equal to the amount the Driver exceeds 185 pounds.

14.4.2.5. The Driver ballast weight tolerance is 0.00 to + 1.00 pounds. The Driver Equivalency Weight must be installed and secured in the designed location forward of the seatback. This location may only be used for Driver ballast.

14.4.2.6. In addition to the above specified location, a 10-pound (tolerance 0.00 to + 0.50 pounds) Driver ballast weight may be added to the front face of the pedal bulkhead as per approved drawing supplied by Dallara. This location may only be used for Driver ballast and only for Drivers requiring 10 pounds or more ballast.

14.4.2.7. The Driver Equivalency Weight must be a hard-dense metal.

14.4.2.8. Violation of this Rule may result in a minimum \$100,000 fine and/or other penalties.

14.4.2.9. All Drivers are reweighed at technical inspection within fifteen (15) minutes after completion of practice session one (1) of a Race Event. Drivers must wear the following personal safety equipment: uniform, underwear (top and bottom), socks, and shoes.

14.4.2.9.1. A Driver late for weigh in loses ten (10) minutes from the end of the next practice session.

14.4.2.9.2. A Driver failing to appear for weigh in may not participate in practice and/or Qualifications until he/she has completed the weigh in.

14.4.2.10. Driver ballast changes are subject to the following:

14.4.2.10.1. A Driver weight change of plus or minus 3 pounds: Car and/or Driver weight will remain unchanged, and Entrants may not change their Driver ballast.

14.4.2.10.2. A Driver weight change of more than plus or minus 3 pounds: Entrants must change their Driver ballast before the current Race's Qualifications.

14.4.3. A Driver weight change of more than plus or minus 7 pounds: Entrants may be subject to penalty

## 14.5. Chassis

14.5.1. Timing Transponder – The timing transponder must be used in the designated location as supplied by INDYCAR at all times.

14.5.2. Mirrors Lens – The minimum mirror glass dimension is 6.000 inches wide by 2.000 inches tall with a corner radius of 0.375 inches. No portion of the mirror lens may be recessed in the mirror housing by more than 0.250 inches. The standard Dallara mounting location for the lens must not be moved and the housing must be trimmed to comply with the 0.250-inch dimension.

14.5.3. Mirror housing must be used as supplied and in the designated location, adhere to the following Technical Inspection dimensions:

14.5.4. Windscreen – All windscreens must be submitted to INDYCAR via IRIS for approval prior to use.

### 14.5.5. Car Tracking System, In-Car Cameras and On-Board Video Equipment

14.5.5.1. Car Tracking System – The INDYCAR-approved car tracking system must be installed in the designated location(s) on each Car and must be operational at any time the Car is participating in on-Track Events.

14.5.5.2. In-Car Cameras – Upon INDYCAR's request, on-board cameras must be used as supplied by Broadcast Sports, Inc. If INDYCAR does not request an on-board camera be used, dummy camera equipment must be used.

14.5.5.3. On-Board Video Equipment – Entrants must utilize only the AIM on-board camera (XA1SGPH22PB840106U) during all on-track activities. The camera must be mounted per Dallara in the designated location. may use their own on-board camera during non-televised practice sessions only. If used, it must be mounted directly in front of the rollhoop camera location and the mounting must be pre-approved by INDYCAR.

14.5.6. Additional Cameras – Any additional camera may only be used with prior INDYCAR approval.

## 14.6. Dimensions

### 14.6.1. Wheelbase

14.6.1.1. The maximum wheelbase is 121.500 inches and minimum is 117.500 inches.



14.6.1.2. The wheelbase of the Car, left to right, may have a maximum variance of 0.750 inch.

**14.6.2. Track Width (measured at axle center line)**

14.6.2.1. A maximum shim of 4mm may be used under the top rear wishbone studs and the rear toe link studs only. Spacers must be the same thickness for both front and rear wishbone legs.

14.6.2.2. Oval Events – Front and rear are limited to a minimum of 75.750 inches and a maximum of 76.750 inches.

14.6.2.3. Road & Street Course Events – Front and rear are limited to a minimum of 75.500 inches and a maximum of 76.500 inches.

**14.6.3. Track Width Offset**

14.6.3.1. Oval Events – The Car can be between 0.150 inches off center to the left or 0.600 inches off center to the right.

14.6.3.2. Road & Street Course Events – A maximum of plus or minus 0.250 inches is permitted left or right of center.

**14.7. Aerodynamics**

14.7.1. Engine installation components must be used as supplied without modification.

14.7.2. Radiator screens must be installed during all on-track activities.

14.7.3. All aerodynamic components must be run symmetrically except the following:

- Road / Street & Short Oval front wing flap angles
- Speedway front wing end plate angles
- Speedway front mainplane inboard trailing edge extension
- Speedway front wing wickers
- Radiator blanking
- Brake duct blockers
- Underwing sidewalls
- Underwing strakes

14.7.4. Attachments or devices that are movable or adjustable while the Car is in motion and which may affect airflow or aerodynamics are not permitted.

**14.7.5. Wickers**

14.7.5.1. Wickers must be used as supplied by Dallara without modification.

14.7.5.2. The only form of fastener permitted for wicker attachment is bolts. No tape or adhesive is permitted.

**14.7.6. Front Wing**

**All Events**

14.7.6.1. The complete front wing assembly must be used as supplied without modification.

14.7.6.2. Paint, adhesive film, or any other substance may not be added to the underside of the mainplane from a point two (2) inches behind the leading edge of the wing to the trailing edge of the wing.

14.7.6.3. Shimming of the front wing mainplane is permitted to achieve heights and wing angle within the Rules.

14.7.6.3.1. Endplate mounting holes may be modified to accept top-hat bushings; provided the endplate, wing flaps and mainplane remain in the designed location.

14.7.6.4. Front wing configuration must be as listed in the Race Location Specific chart below:

	Description	Commercial Part Number	Indy	Texas <sup>+</sup>	Pocono	Short Oval	Road Course
Front Wing	Front Wing Mainplane SW Wicker H3/8" - STEP 1	IR1804A032/33	O	O	O	U	U
	Front Wing Mainplane SW Wicker H3/8" - STEP 2 **	IR1804A034/35	O	O	O	U	U
	Front Wing Mainplane SW Wicker H3/8" - STEP 3 **	IR1804A036/37	O	O	O	U	U
	Front Wing Mainplane SW Wicker H3/8" x Full Span	IR1804A038/39	O	O	O	U	U
	Front Wing Endplate SW	IR1804A010/11	M	M	M	U	U
	Front Wing Mainplane Trailing Edge Extension SW	IR1804A041/42	O	O	O	U	U
	Front Wing Mainplane Ext. SW Wicker H3/8" - STEP 2	IR1804A043/44	O	O	O	U	U
	Front Wing Mainplane Ext. SW Wicker H3/8" - STEP 3	IR1804A045/46	O	O	O	U	U
	Front Wing Mainplane Trailing Edge Extension RC	IR1804B032/33	U	U	U	O	O
	Front Wing Lower Flap RC	IR1804B015/16	U	U	U	M	M
	Front Wing Upper Flap RC	IR1804B013/14	U	U	U	U	O
	Front Wing Upper Flap Wicker RC	IR1804B011/12	U	U	U	U	O

M= Mandatory  
O= Optional  
U= Unapproved

\* Cannot be used with Mainplane Extension  
\* Subject to additional restrictions

**Road / Street & Short Oval Events**

14.7.6.5. Front wing must adhere to the following Technical Inspection dimensions:

	Width (")	Max	Min
Road Course & Short Oval Front Wing	Outside to outside FWEPs	76.115	76.015
	Inside to inside FWEPs	62.625	62.525
	Inside to inside FW inner flap support	28.950	28.850
	<b>Set Back (")</b>		
	"O" line to FWMP TE	13.775	13.675
	<b>Height ("to Oz)</b>		
	Bottom FWMP		2.850
	Top of FWEP	16.755	
	Bottom of FWEP		2.875
	<b>Angle (°)</b>		
	Mainplane	2.07	1.77
	<b>Deflection (")</b>		
	Mainplane @ 75lb. load	0.300	

Dimensions based on CAD and subject to change

**Indianapolis 500® Mile Race & Speedway Events**

**14.7.6.6.** The bottom of the mainplane must not be less than 4.330 inches above the technical reference plane when the mainplane is set to 0°.

**14.7.6.6.1.** For the purposes of technical inspection, the front wing must not measure less than 8.300 inches when set at any angle, while installed on the INDYCAR technical inspection fixture.

**14.7.6.7.** Front wing must adhere to the following Technical Inspection dimensions:

		Width (")	Max	Min
<b>SW Front Wing</b>	Outside to outside FWEPs		70.090	69.990
	Inside to inside FWEPs		56.320	56.220
	<b>Set Back (" w/FWEP @ 0.0°)</b>			
	"O" line to FWEP TE		0.285	0.185
	<b>Height (" to Oz w/FWEP @ 0.0°)</b>			
	Top of FWEP		12.250	
	Bottom FWEP			2.590
	<b>Angle (°)</b>			
	FWEP			-1.50
	<b>Deflection (")</b>			
	Mainplane @ 50lb. load		<b>TBD</b>	

Dimensions based on CAD and subject to change

### 14.7.7. Rear Wing

#### All Events

14.7.7.1. The complete rear wing assembly must be used as supplied without modification.

14.7.7.2. The top surface of the mainplane must be covered with a one-piece decal wrap. The mainplane wrap must start at the trailing edge and extend one (1) inch around the leading edge of the lower surface. For Events utilizing the speedway rear wing, the top surface of the wing will end where the radius begins for the endplates. The mainplane wrap may have printing and decals applied, provided the printing or decals are approved by INDYCAR prior to use.

14.7.7.3. One 2.0-inch strip of helitape may be placed along the leading edge of the mainplane, provided it is applied 1.0 inch below and 1.0 inch above the centerline of the leading edge of the mainplane. The rear wing mainplane may not be painted.

14.7.7.4. During initial technical inspection at each Open Test and Race, the rear wing mainplane must be presented without the mainplane wrap, if requested by INDYCAR.

14.7.7.5. Shimming of the rear wing mounting blocks is permitted to achieve heights, set-back and wing angles.

14.7.7.6. Rear wing configuration must be as listed in the Race Location Specific chart below:

	Description	Commercial Part Number	Indy	Texas <sup>+</sup>	Pocono	Short Oval	Road Course
<b>Rear Wing</b>	Rear Wing Mainplane SW	IR1805B001	M +2.0° Max	M -3.0° Max	M +2.0° Max	U	U
	Rear Wing Adjuster Kit	IR1205D017	M	M	M	U	U
	Rear Wing Mainplane SW Wicker - 3/8" x 13.2"	IR1805B008	O	U	O	U	U
	Rear Wing Mainplane SW Wicker - 3/8" x 24.5"	IR1805B007	O	U	O	U	U
	Rear Wing Mainplane SW Wicker - 3/8" x Full Span	IR1805B002	U	U	O	U	U
	Rear Wing Flap RC (Lower Position)	IR1805C011	U	U	U	M	M
	Rear Wing Flap RC (Upper Position)	IR1805C011	U	U	U	U	O
	Rear Wing Flap RC Wicker - 3/8" *	IR1805C015	U	U	U	O	O

M= Mandatory  
O= Optional  
U= Unapproved

\* Only allowed on lower position if upper position is not fitted  
\* Subject to additional restrictions

**Road / Street & Short Oval Events**

14.7.7.7. Rear wing must adhere to the following Technical Inspection dimensions:

		Max	Min
<b>Road Course &amp; Short Oval Rear Wing</b>	<b>Width (")</b>		
	Outside to outside RWEPS	44.755	44.655
	Inside to Inside RWEPS (excluding louvers)	43.335	43.235
	RWEP TE Thickness	0.730	0.690
	<b>Set Back (")</b>		
	"O" Line to TE RWMP	162.060	161.960
	Diff CL to TE RWEP	167.240	167.140
	<b>Height ("to Oz)</b>		
	Top of RWEP	33.910	
	Bottom of RWEP		10.285
	Top of RWMP TE	28.115	28.015
	Top of Flap (H6 2 Elem)	33.435	
	Top of Flap (H6 1 Elem)	30.235	
	<b>Angle (°)</b>		
	Mainplane	0.50	-0.50
	<b>Deflection (")</b>		
	Mainplane @ 250lb. load	0.100	
	Flap @ 100lb. load	<b>TBD</b>	
	<b>Trailing Edge Thicknes (")</b>		
	Mainplane	0.100	0.060
	Flap	0.100	0.060
	<b>Slot Gaps</b>		
	1 <sup>st</sup> to 2 <sup>nd</sup> Element	0.320	0.265
Mainplane to 1 <sup>st</sup> Element H6 -> H4	0.360	0.310	
Mainplane to 1 <sup>st</sup> Element H3 -> H1	0.345	0.295	

Dimensions based on CAD and subject to change

**Indianapolis 500® Mile Race & Speedway Events**

14.7.7.7.1. Rear wing adjuster is mandatory and the Dallara-supplied lock nuts to limit travel must be installed, when applicable.

14.7.7.7.2. The Rear wing mainplane must not have more than 0.100 inches of tilt in the “Y” coordinate.

14.7.7.7.3. Rear wing must adhere to the following Technical Inspection dimensions:

		Width (")	Max	Min
SW Rear Wing	Outside to Outside RWEPs		52.300	52.200
	<b>Set Back (" w/RWMP @ -3°)</b>			
	Diff CL to TE RWMP on Car CL		23.950	23.850
	<b>Height (" to Oz w/RWMP @ -3°)</b>			
	Bottom of RWEP (@-3°)			21.430
	TE Height of RWMP (at all approved angles)		27.375	27.225
	<b>Angle (°)</b>			
	Mainplane		Per Event	-9.0
	<b>Deflection (")</b>			
	Mainplane @ 100lb. load		TBD	

Dimensions based on CAD and subject to change

**14.7.8. Bodywork & Underwing**

14.7.8.1. The complete bodywork, underwing and underwing stays must be used as supplied without modification.

14.7.8.1.1. Holes that do not exceed .375 inches may be added to the underwing or underwing parts for hardware access. Holes must be covered during on-track activities.

14.7.8.2. The inboard bell housing and gearbox stays must be used as supplied and fixed in the neutral position.

14.7.8.3. Standard bodywork and underwing as supplied in technical inspection must be able to fit and be fastened at any time, using all original fasteners.

14.7.8.4. No paint may be added to the underwing surface from a point 2.000 inches behind the leading edge of the underwing. From this point after, only clear coating may be applied.

14.7.8.5. Ballast cannot be bolted or bonded to the underwing.

14.7.8.6. All included fasteners must remain and be in the locations as delivered.

14.7.8.7. Tape may be applied to bodywork and chassis junctions or openings providing there is no change to the intended shape or profile of the original part.

14.7.8.7.1. Tape or covering may not be applied to the nose camlock holes, access holes through the engine cover to the attenuator camlocks, tow bar holes or; nose to chassis. shock cover to chassis or the headrest to chassis split lines.

14.7.8.8. The right-side NACA Duct in the Underwing Top Panel RH (IR1803A015) must remain open, the Bellhousing Cooling Duct (IR1803A023) and Bellhousing Cooling Duct Flange (IR1803A024) must be installed and the airflow unrestricted.

14.7.8.9. The left-side NACA Duct in the Underwing Top Panel LH (IR1803A016) must remain open and the airflow must remain unrestricted. Internal ducting of the air is open for team use.

14.7.8.10. Only homologated radiator blanking may be used. Holes in the blanking panel for mounting bolt access are permitted, provided they are covered during on-track activities.

14.7.8.11. Approved external IR tire temperature sensor mounting locations:

14.7.8.11.1. The front IR tire temperature sensor must be mounted to the underwing, under the Underwing Hole Front Panel SW IR1803A07/08 or Underwing Hole Front Top Panel RC IR1803A11/12. The covers must have a window designed to return them to their original shape.

14.7.8.11.2. The rear IR tire temperature sensor must be mounted in the Underwing Rear Blanking Panel IR1803A17/18.

14.7.8.12. Bodywork and underwing configuration must be as listed in the Race Location Specific Charts below:

	Description	Commercial Part Number	Indy	Texas	Pocono	Short Oval	Road Course
<b>Bodywork</b>	Radiator Duct Blanking *	IR1802A010/11 or trimmed as homologated by Engine manufacturer	O	O	O	O	O
	Radiator Rear Face Blanking	As homologated by Engine manufacturer	O	O	O	O	O
	Sidepod LH Side Blanking Panel	IR1802A024	M	M	M	M	M
	Tyre Ramp SW	IR1802A019/20	M	M	M	U	U
	Tyre Ramp RC	IR1802A021/22	U	U	U	M	M
	Tyre Ramp RC Wicker	IR1802A015/16	U	U	U	M	M
	Tyre Ramp Lower Part RC Wicker	IR1802A017/18	U	U	U	M	M

**M= Mandatory**

**O= Optional**

**U= Unapproved**

\* No coatings except Helicopter tape allowed.

	Description	Commercial Part Number	Indy	Texas <sup>+</sup>	Pocono	Short Oval	Road Course
<b>Underwing</b>	Underwing Side Wall	IR1203A007/08	O	U	O	O	O
	Underwing Side Wall - Trimmed	IR1203A007/08	O	U	O	O	O
	Underwing Strake Z-30	IR1203A003/04	U	U	O	O	O
	Underwing Strake Z-15	IR1803A013/14	U	U	U	O	O
	Underwing Hole Rear Panel SW	IR1203A037/38	M	M	M	U	U
	Underwing Hole Front Panel SW	IR1803A007/08	M	M	M	U	U
	Underwing Hole Rear Panel RC	IR1803A005/06	U	U	U	M	M
	Underwing Hole Front Bottom Panel RC	IR1803A009/10	U	U	U	M	M
	Underwing Hole Front Top Panel RC	IR1803A011/12	U	U	U	M	M
	Underwing Trailing Edge Flap	IR1803D001/02	M	M	M	U	U
	Underwing Trailing Edge Wicker H 1"	IR1803A025	U	U	U	O	O
	Underwing Packer Z-20	IR1803A003/04	M	M	M	M	U
	Underwing Reverse Wicker	IR1803A028/29	U	M	U	U	U

**M= Mandatory**

**O= Optional**

**U= Unapproved**

\* Subject to additional restrictions

14.7.8.13. Bodywork & underwing must adhere to the following Technical Inspection dimensions:

	Width	Max	Min
Tire Ramps	Outside to Outside Tire Ramps RC	78.140	78.040
	Outside to Outside Tire Ramps SW	77.605	77.505
	<b>Height (to Oz)</b>		
	Top of Tire Ramp RC	24.325	24.225
	Top of Tire Ramp SW	25.945	25.845

Dimensions based on CAD and subject to change

	Width	Max	Min
Underwing	Outside to Outside	79.050	78.950
	<b>Height (to Oz)</b>		
	Underwing Exit	7.650	7.550
	<b>Deflection (")</b>		
	Front @ 75lb.	0.275	
	Rear @ 75lb.	0.200	

Dimensions based on CAD and subject to change

14.7.8.14. Bodywork Fitting

14.7.8.14.1. The following parts may be blended to reduce uneven surfaces and gaps. Hard edges may be tapered or blended. These parts must remain separate parts and there must be a distinct joint line defining each part from its mounting surface or part(s). They must detach from their mating part(s) with the removal of the Tridairs or bolts. All intended shapes and radii must remain as designed. No tongue-and-groove, dovetail, or other types of body fitting will be permitted. Extra fasteners are permitted.

14.7.8.14.1.1. The Roll Hoop Cover,

14.7.8.14.1.2. Sidepods,

14.7.8.14.1.3. Structural Front Sidepods,

14.7.8.14.1.4. Refueling Panels (may have material added to the inside surface for additional strength),

14.7.8.14.1.5. Refueling Panel Covers,

14.7.8.14.1.6. Engine Cover (Kevlar patches may be added to improve TPMS data reception),

14.7.8.14.1.7. Damper Cover,

14.7.8.14.1.8. Tire Ramps,

14.7.8.14.1.9. Mirrors,

14.7.8.14.1.10. Underwing leading edge to tub,

14.7.8.14.1.11. Rad Boxes,

14.7.8.14.1.12. Top Center Part of the underwing (may be sectioned in the designated location), and

14.7.8.14.1.13. Fuel funnel faring (refueling Buckeye sleeve) and the lower portion may be modified to fit the sidepod profile.

14.7.8.14.2. The following parts and any bodywork or underwing part not listed may not be fit as above, sanding to improve fit is permitted. All other types of body fitting are prohibited. These parts may be installed using silicone or 2-sided tape provided it does not change the installed height by more than 0.020 and they must use the supplied fasteners. The silicone must not be seen when viewing the part from any angle. Extra fasteners are permitted.

14.7.8.14.2.1. Underwing packers,

14.7.8.14.2.2. all underwing leading edge and trailing edge covers (holes may be added in the cover to access the underwing support hardware),

14.7.8.14.2.3. underwing strakes and sidewalls,

14.7.8.14.2.4. underwing flaps and flap parts, and

14.7.8.14.2.5. engine cover fin.



14.7.8.14.2.6. underwing flip-ups

- Must have a fluorescent yellow stripe (six (6) inches tall by four (4) inches wide) on the bottom side of the flip-up, which becomes visible when the flaps are deployed.

14.7.8.14.3. The monocoque reinforcement extension, the anti-intrusion panel, the 2014 chassis reinforcement panels and the 2015 FLWB anti-intrusion plate (Dallara etching must remain visible) may be blended until there are no distinctions between parts.

14.7.8.14.4. The headrest to the chassis cockpit rim interface may be blended and the height of the headrest may be adjusted to provide an even surface, provided no material is added to the headrest.

14.7.8.14.5. The following may be blended until there is no distinctions between parts:

14.7.8.14.5.1. Center Line Wicker – The center line wicker attached to the nose and chassis

14.7.8.14.5.2. Left-Hand Side Pod Louver Cover

14.7.8.14.5.3. AiM Camera mount

14.7.8.14.5.4. Nose camera mount

14.7.8.14.6. Bodywork flanges may be trimmed for plumbing and wire clearance, provided the bodywork integrity remains.

14.7.9. Underwing

14.7.9.1. The underwing step plane heights must adhere to the following illustration. The heights have a tolerance of plus 0.100 inches and minus 0.100 inches.

14.7.9.2. The underwing tunnel exit height must adhere to the following illustrations. The height has a tolerance of plus 0.050 inches and minus 0.050 inches.

Road / Street

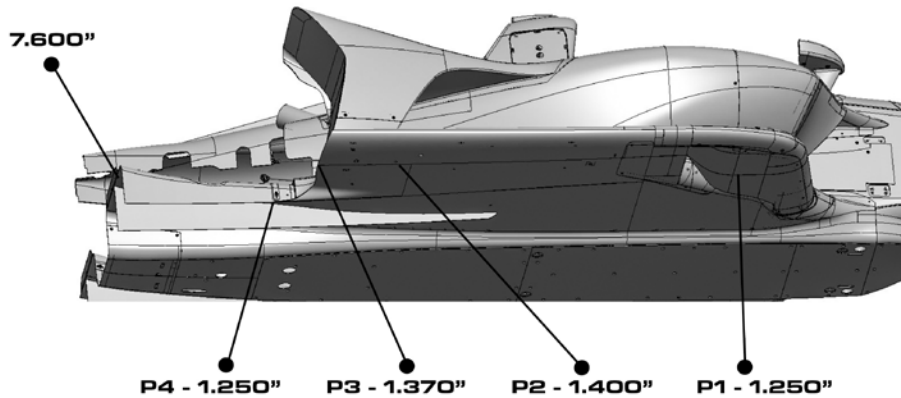

Short Oval Events

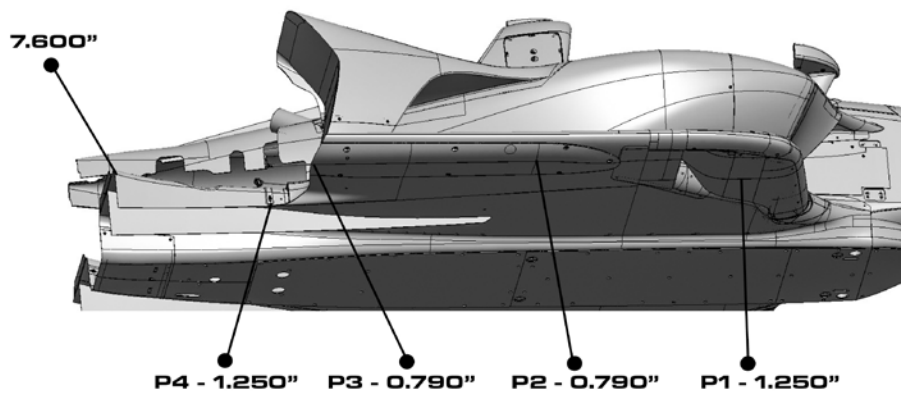

Indianapolis 500® Mile Race & Speedway Events

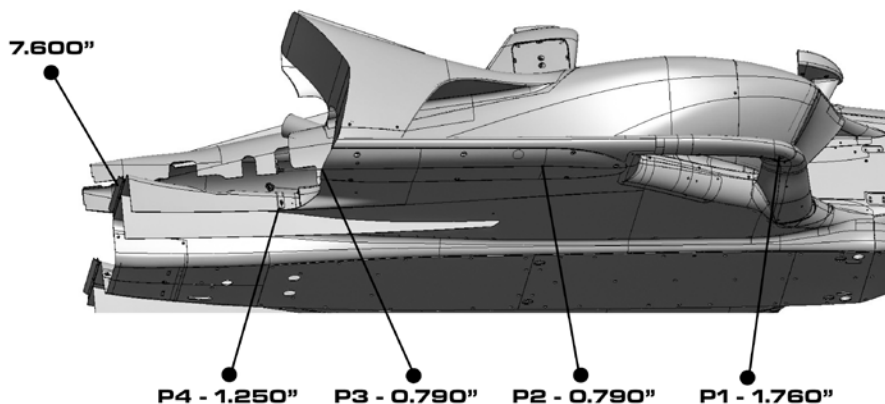

**14.7.10. Skids**

- 14.7.10.1. Skids must be made to the drawings supplied by Dallara. “X” coordinate split lines may be moved, and original puck holes may be removed.
- 14.7.10.2. Skids must be made from 3.0mm material or 0.125-inch material.
- 14.7.10.3. Approved materials are brass, carbon, stainless steel, aluminum, jabroc and plastic.
  - 14.7.10.3.1. One-piece skids are permitted.

**14.8. Fuel System**

- 14.8.1. The fuel system must be used as supplied by Dallara, with the following exceptions:
  - 14.8.1.1. Standard elephant trunk (IR1214C002) must be used but the foot may not be less than 3.000 inches from the floor of the fuel cell. Breather holes may be added or removed.
  - 14.8.1.2. Standard fuel bladder vent (IR1214C001) must be used but can be modified for fuel cell height. Breather holes may be added or removed.
  - 14.8.1.3. Plumbing of the fuel cell lines are open to development.
  - 14.8.1.4. Filters may be added or changed.
  - 14.8.1.5. Pressure sensors may be added provided they otherwise comply with the Rules.
- 14.8.2. The maximum capacity of the fuel cell shall be 18.500 U.S. Gallons.
  - 14.8.2.1. The only approved method of fuel cell volume reduction is by the addition of fuel cell airtight balls inside the fuel cell.
- 14.8.3. Lanyard-secured self-sealing breakaway valves must be used on the supply and return lines. All installations are subject to the approval of INDYCAR.
- 14.8.4. In the event a fuel cell buckeye is not being utilized at a Race Location, a blanking plate with a minimum thickness of 0.250 inches must be securely fitted utilizing all of the holes in the fuel cell.

**14.9. Steering and Suspension**

- 14.9.1. Steering wheels must incorporate an approved quick release mechanism (Rule 18.1.17.).
- 14.9.2. Only the Dallara supplied parts and rack and pinion options may be used. Modifications to the pinion bearing are permitted with INDYCAR approval.
- 14.9.3. Only the Dallara supplied suspension parts may be used. Steel steering arms may be updated to the Dallara drawing referenced below.

	Part Number	DWG Number
S. Arms	IR1206H004	IR1255103
	IR1206H005	IR1255107
	IR1206H006	IR1255116

- 14.9.4. Suspension parts may not be controlled or activated electronically, with the exception of the weight jacker.
- 14.9.5. One weight jacker may be used at Oval Events only. This must be fitted on a rear damper of the Car with a maximum travel of 0.500 inch. This must be controlled through the approved control box to which no modifications are permitted.

## 14.10. Dampers and Inerters

- 14.10.1. Damper is a mechanical device utilizing hydraulic fluid to dissipate energy.
- 14.10.2. Each corner must have one damper and one conventional spring. Each spring must be comprised of round, steel wire. Closed and/or ground ends are allowed. Helper springs, bump rubbers and packers are permitted, provided they are fitted with the primary spring.
- 14.10.3. Front and rear third control springs, bump rubbers and packers are permitted. No front or rear third dampers, inerters or any other device are permitted nor any modification to the manufacturer supplied parts.
- 14.10.4. Carbon and/or titanium springs are not permitted on the dampers or the front/rear third element.
- 14.10.5. The dampers must operate independently on each corner of the suspension; they must react directly to the input of that corner as connected to the suspension system.
- 14.10.6. The damper must be attached at one end to the chassis mounting point and the other end directly to the suspension rocker.
- 14.10.7. Connecting dampers side-to-side (except through the ARB) or front to rear is not permitted.
- 14.10.8. Dampers cannot be adjusted by the Driver.
- 14.10.9. The damper assembly must be contained within the approved designated volume. This CAD file is available from Dallara.
- 14.10.10. No independent inerters or mass dampers are permitted.

## 14.11. Driveshafts / Hubs

- 14.11.1. Only Dallara parts may be used as supplied.
- 14.11.2. Dallara wheel lock parts must be used as supplied.
- 14.11.3. Upright bearings must be used as specified by Dallara.
- 14.11.4. Bearing spacers (IR1207B015 / IR1209B005) may be machined for bearing pre-load.

## 14.12. Energy Management System (EMS)

### 14.12.1. General

- 14.12.1.1. EMS must be used as supplied by ARCR/Amick Associates and approved by INDYCAR.
- 14.12.1.2. All mounting points must be free of sharp edges.
- 14.12.1.3. The EMS must be replaced if damaged or as required by INDYCAR.
- 14.12.1.4. EMS will be color-coded per production year.

### 14.12.2. Front and Rear Suspension

- 14.12.2.1. Three (3) 100kN EMS per suspension corner mounted as specified by Dallara.
  - 14.12.2.1.1. All Front and Rear Suspension EMS must be color-coded yellow.

### 14.12.3. Nose EMS

- 14.12.3.1. Two (2) 30kN EMS mounted as specified by Dallara. The Dallara-supplied mounting block (IR1204A026) may be bolted or adhered to the bulkhead.

### 14.12.4. Nosebox Locking Shaft EMS

- 14.12.4.1. Two (2) 30kN EMS connecting the left and right-side shafts

### 14.12.5. Front Wing EMS

- 14.12.5.1. One (1) 30kN EMS connecting the left and right front wing mainplane as specified by Dallara.

### 14.12.6. Rear Wing EMS

- 14.12.6.1. All Events – One (1) 100kN EMS between the attenuator and the gearbox
- 14.12.6.2. Road Course / Street & Short Oval Events – One (1) 100kN EMS between the mainplane and the attenuator
- 14.12.6.3. Indianapolis 500® & Speedway Events – One (1) 30kN EMS between the mainplane and the attenuator

### 14.12.7. Underwing EMS

- 14.12.7.1. One (1) 30kN EMS per side mounted as specified by Dallara.

### 14.12.8. Camera and Dummy Camera EMS

- 14.12.8.1. One (1) 30kN EMS attached to the front camera / dummy camera, mounted as specified by Dallara
- 14.12.8.2. One (1) 30kN EMS attached to the rear camera / dummy camera, mounted as specified by Dallara

### 14.12.9. Mirror EMS

- 14.12.9.1. One (1) 30kN EMS per side mounted as specified by Dallara

## 14.13. Brakes

### All Race Locations

14.13.1. Brake ducts must be used as supplied without modification.

14.13.1.1. Unused holes or gaps may be filled. To access the brake caliper bleeder, a hole 0.375-inch or less may be added to the brake duct backing plate. This hole must be covered during on-track activities.

14.13.1.2. Ducts may be extended inward (towards rotor), provided there is no change to the intended shape.

14.13.2. Only brake parts as supplied by Approved Suppliers and approved by INDYCAR are allowed.

14.13.2.1. PFC – discs, pads and disc bells

14.13.2.1.1. Brake disc and pad thickness

14.13.2.1.1.1. The minimum disc thickness is 0.866 0.826 inches.

14.13.2.1.1.2. The minimum pad thickness is 0.472 0.433 inches.

14.13.2.2. Brembo – master cylinders

14.13.2.2.1. A migration system (consisting of a spring perch, spring, packers and washers) applied to the master cylinder push rod is permitted.

14.13.2.3. Dallara – disc guards

14.13.3. Cars must be equipped with a dual-braking system to operate the brakes effectively on all four (4) wheels. The use of computer logic to control any function of the braking system is not permitted.

14.13.4. The only permitted form of brake bias adjustment is through the Dallara-supplied system.

14.13.4.1.1. Any relocation of the brake bias adjustment knob must be submitted to INDYCAR via IRIS for approval.

14.13.5. The PFC pad-retraction system is the only device designed to push or pull back caliper pistons or pads that is approved for use. Pull back brakes in any other form are not permitted.

14.13.6. Only tape, flat panels, or panels that follow the front contour of the brake duct or brake snorkel may be used as blockers to regulate the airflow into the brake duct or brake snorkel.

14.13.7. The following Dallara brake disc guards must be used:

- Front IR1210E007 / 08 – as supplied
- Rear IR1810H012 / 13 – as supplied or trimmed 1.00 inch per illustration

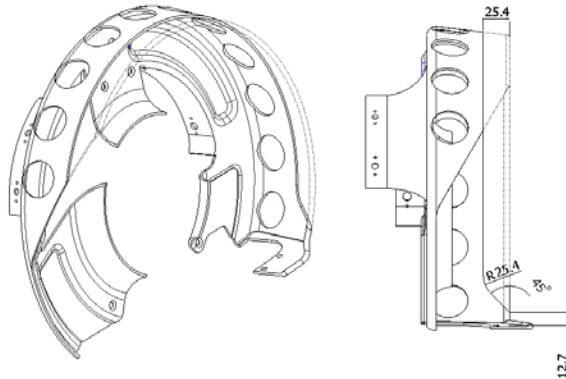

14.13.8. Brake duct configuration must be as listed in the Race Location Specific Chart below:

		Description	Commercial Part Number	Indy	Texas	Pocono	Short Oval	Road Course
<b>Brake Ducts</b>		Front Backing Plate	IR1210E001/02	M	M	M	U	U
		Rear Backing Plate	IR1210H001 to 11	M	M	M	U	U
		Front Brake Ducts *	I15-002-0003/04** or D2H080-001F3-00291-B/92	U	U	U	M	M
		Front Interface Panels	D2H080-001F3-00293/94	U	U	U	O	O
		Caliper Ducts	D2H080-001F3-00295/26	U	U	U	O	O
		Rear Brake Duct	I15-Q02-0001/02*** or D2H080-001R3-00301-B/02	U	U	U	M	M
		STD Infill Panel LH	D2H080-001R3-00385	U	U	U	U	M
		Short Oval Infill Panel LH	D2H080-001R3-00386	U	U	U	M	U
		Rear Duct Interface Panels	D2H080-001R3-00305/06	U	U	U	O	O
		Rear Aux Duct	I15-Q02-0003/04 or D2H080-001R3-00303/04	U	U	U	O	O
		Brake Disc Cooling Hat	D2H080-001F1-00544-B	O	O	O	O	O

M= Mandatory

O= Optional

U= Unapproved

\* No backing plate

\*\* Must be updated per D2H Technical Memo 1.1

\*\*\* Must be updated per D2H Technical Memo 2.1

#### 14.14. Wheels

14.14.1. Wheels must be used as supplied without modification.

14.14.2. The rim width for front wheels is limited to 10.000 inches. The rim width for rear wheels is limited to 14.000 inches.

14.14.3. The only wheel designs approved by INDYCAR are BBS and, OZ and Avus. Only INDYCAR-approved finishes may be used on wheels.

14.14.4. The use of wheel covers or inserts is prohibited.

14.14.5. Any machining or modification of an approved wheel requires the approval of INDYCAR.

14.14.6. The wheel offset may not be modified from design. Subject to Rule 14.14.5, the wheel may be shimmed to bring the wheel back to the designed specification (with the addition of a spacer). The following tolerance must be adhered to when measuring from the high point of the wheel inboard flange to the wheel mounting face.

- Front wheel min. 6.125", max. 6.225"
- Rear wheel min. 7.750", max. 7.850"

14.14.7. Wheels must be NDT (non-destructive testing) inspected by an INDYCAR-approved inspection station prior to the Entrant's first on-Track Event, prior to the Indianapolis 500<sup>®</sup> Mile Race Event and prior to the Pocono Event.

14.14.8. The service life of wheels is six (6) years from the in-service date, or the equivalent of six (6) years in service use. Wheels may only be used beyond the six (6) year period with INDYCAR approval. Wheels used only at the Indianapolis 500<sup>®</sup> Mile Race will be considered to have used ½ of a year's wheel life.

14.14.9. A copy of all wheel serial numbers must be submitted to INDYCAR for approval before the designated on-Track Events. Serial numbers must be visible while wheel is mounted on Car.

14.14.10. Tire pressure bleeding must be done manually, through the Schrader valve, and only while the Car is stationary.

#### 14.15. Heating and Cooling

14.15.1. No forms of heating may be used on a Car when the Car is outside its assigned garage.

14.15.2. The following forms of cooling are permitted:

14.15.2.1. At any time:

- a) Cooling towels applied to bodywork,
- b) Driver cooling fans,

- c) Self-contained, battery-powered electronic box cooling fans through the supplied electronics inlets or direct application only (must be submitted to INDYCAR via IRIS for approval),

**14.15.2.2.** In assigned Pit Box only:

- a) Brake cooling fans,
- b) Electronic box cooling fans, through the radiator inlets or direct application only.

**14.15.2.3.** In assigned Garage only:

- a) Blown ambient air with up to two (2) fans that have ducts or shrouds extending no further out than one (1) times the diameter of the fan blades in either direction (measured from the center of the fan) and the air may not be cooled in any form as it passes through the fan. The fans can only be used to flow air into the front of the radiator boxes. No component may be installed, nor any fluid may be added to the Car at any time at a temperature below that of the ambient air with the exception of the Driver's drink bottle. Use of chemicals to cool the air and/or Car components is also prohibited.

**14.15.3.** Cooling the inside of the fuel cell is not permitted at any time.

**14.15.4.** Thermostats – Thermostats or bypass valves are not permitted on any cooling system.

**14.16. Gearbox/Differential**

**14.16.1.** Only gearbox parts and gear ratios provided by Xtrac may be used with the exception of Rule 14.16.3.c.

**14.16.2.** Treatments and coatings are open to development; the Xtrac logo/etching must remain on all original parts.

**14.16.3.** Original rotary lip seals that are etched with the Xtrac part number and logo must be used as below:

- a) 00P-100-0111A, 40x52x7 Lipseal, Used in Front Cover (Input Shaft) and Rear Cover (Starter Shaft).
- b) 00P-100-0109A, 98x120x12 Lipseal, Used in Side Cover (LH Output Flange) and Maincase (RH Output Flange).
- c) Remaining gearbox seals are open.

**14.16.4.** The approved paddle shift gear selection system must be used at all Race Locations. The paddle shift system must be used as supplied. The paddles may be extended, and a simple system added to increase driver feel. Any modifications must be submitted to INDYCAR via IRIS for approval.

**14.16.5.** Only the following CCUs (clutch control units) are permitted and must be used as supplied:

- a) Megaline E-CCU 195-0009, bracket E-CCU 1011-919-000C and corresponding looms
- b) Shiftec CZM022-3

**14.16.5.1.** Air pressure accumulator IR1217F006 must be run with any CCU.

**14.16.6.** The gearbox must maintain all six (6) fully meshed gears during an on-Track Event. Reverse gear must be operational throughout all on-Track Events.

**14.16.7.** Entrants must provide seal locations comprised of two (2) drilled holes with a minimum of 0.032 inches in each of the following locations:

- c) Gearbox to bellhousing
- d) Gearbox rear and side covers
- e) Bellhousing to the Engine
- f) Engine to the bulkhead

**14.16.8.** All parts of the differential assembly must be used as supplied without modification by Xtrac.

	Part	Part Number	Mandatory (M)	Optional (O)
Xtrac Differential Parts	Septa Seal	109-0350	–	O
	Modified Grub Screw	00P-137-0043A	–	O
	Disc Spring	00P-190-0028	–	O
	Quad Ring Seal	109-0348	M	–
	Quad Ring Seal	109-0349	M	–
	Preload Piston	1011-449-012A	M	–

**14.16.9.** The differential clutch stack may be re-arranged and any combination of 10 total friction (199-290-007A) and drive plates (094-290-008A) may be used, provided all parts remain as supplied.

**14.16.10.** The disc spring (00P-190-002B) is available in multiple stiffnesses from Xtrac and are all approved for use. The disc spring must remain on the right side of the differential assembly in the Xtrac approved location and shimming is not permitted.

**14.16.11.** The side gear ring (ramps) and cross pin must be used as supplied.

**14.16.12.** The preload piston is permitted to have inert gas, air or fluid behind the preload piston.

14.16.13. At Oval Events either an Xtrac supplied spool or differential with blocker must be used.

14.16.14. The gearbox must be vented to the atmosphere.

#### 14.17. Airjack

14.17.1. Entrants must leave the airjack receptacle in the INDYCAR-approved location.

#### 14.18. Electronics

##### 14.18.1. General

14.18.1.1. The only approved electronics for data logging is the Cosworth Omega system which includes the following:

- Central Logging Unit (CLU)
- Removable Logger Unit (RLU)
- Synchronous Junction Unit (SJU)
- Configurable Display Unit (CDU) with a CAN Switch Board (CSB) or the CAN Carbon Wheel (CCW) MkII
- Intelligent Power System (IPS32)

14.18.1.2. Teams are free to design their own steering wheel electronics, but must integrate the approved Cosworth display.

14.18.1.2.1. All input switches on the steering wheel must indicate their position directly through the Cosworth CAN Switch Board (CSB) without any control interruption of the physical position of the switch.

14.18.1.3. Entrants must not connect to the Car until released by INDYCAR at the completion of Qualifications, the Race, and/or as directed by INDYCAR.

14.18.1.4. Entrants must maintain a system voltage of at least 13 Volts at all times while the Car is running on-track.

14.18.1.5. INDYCAR-specified devices and control units may not be powered down, supplied improper voltage or disconnected while the Car is running on-track.

14.18.2. Only the following on-board Car batteries are permitted and must be used as supplied:

- a) EarthX Indy6
- b) Braille ML7Ti.v2

##### 14.18.3. Ignition Switch

14.18.3.1. All Cars must be equipped with an ignition switch that can be activated by the Driver. The ignition switch must be clearly marked.

##### 14.18.4. Fire Bottle Switch

14.18.4.1. The Dallara supplied fire bottle switch must remain in the specified location.

##### 14.18.5. Master Switch

14.18.5.1. The master switch must be used as supplied by Dallara.

14.18.5.2. The switch must energize the on-board fire extinguisher and shut off the ignition.

14.18.5.3. The switch must be clearly marked by a decal supplied by INDYCAR. Entrants must not disconnect the switch.

14.18.5.4. When a master switch is pulled, it must remain in that state until manually reset.

##### 14.18.6. Rain Lights

14.18.6.1. Only the Dallara-supplied rain light may be used.

14.18.6.2. The assembly must be mounted to the attenuator in the INDYCAR-specified location.

##### 14.18.7. Electronic Logic Processors

14.18.7.1. The use of electronic logic processors or devices to mechanically or electronically control any Car function or to activate or to interrupt direct input or control from the Driver to an INDYCAR-approved control unit is not allowed, except for INDYCAR-approved electronic control units. Such approved units include control of the following:

14.18.7.1.1. Engine,

14.18.7.1.2. Clutch,

14.18.7.1.3. Gearbox, and

14.18.7.1.4. Weight jacker.

14.18.7.2. Only INDYCAR-approved data acquisition systems may be used.

14.18.7.3. Electronic data of any type may not be transmitted wirelessly to a Car.

14.18.7.4. The INDYCAR-approved data acquisition system may not be used to activate or to interrupt the direct transmission of Driver inputs and switches to destination INDYCAR-approved electronic control units except for the use of debounce with fixed time parameters, and weight jacker control software inputs. Weight jacker input logic may only include direct input

~~from the Driver and/or weight jacker position. The logic source code must be submitted to INDYCAR via IRIS for prior approval.~~

**14.18.7.5.** A single Driver input may not provide input to or activate multiple control functions.

**14.18.7.6.** Control system override modes must not be used without a clear and readily-identifiable problem including any of the following:

- Increased sensor noise or failure
- Offset signals
- Slow control actuation
- Control fails to actuate

#### **14.18.8. Chassis Sensors**

**14.18.8.1.** The following sensors may only be used as supplied by Approved Suppliers:

**14.18.8.1.1.** Throttle pedal sensor (Cosworth or McLaren);

**14.18.8.1.2.** Gear position sensor (Cosworth or McLaren);

**14.18.8.1.3.** Gearbox temperature sensor (Cosworth, McLaren or Texense);

**14.18.8.1.4.** Front and rear push rod strain gauge (Cosworth or bf1systems); and

**14.18.8.1.5.** Wheel speed sensors (Cosworth, McLaren or Texense)

**14.18.8.2.** The following additional chassis sensors are allowed:

**14.18.8.2.1.** Tire pressure sensors;

**14.18.8.2.2.** Brake pedal position;

**14.18.8.2.3.** Brake master cylinder displacement;

**14.18.8.2.4.** A maximum of two (2), 3-axis chassis accelerometers;

**14.18.8.2.5.** A maximum of four (4) single axis hub accelerometers, 1 per corner;

**14.18.8.2.6.** Strain gauged suspension parts;

**14.18.8.2.7.** Strain gauged steering shaft;

**14.18.8.2.8.** Beacon receiver;

**14.18.8.2.9.** Laser ride height;

**14.18.8.2.10.** Gyro or angular rate sensors;

**14.18.8.2.11.** Roll bar positions;

**14.18.8.2.12.** Weight jacker position;

**14.18.8.2.13.** Clutch position;

**14.18.8.2.14.** Any pressure sensor, limited to diaphragm-type;

**14.18.8.2.15.** Any temperature sensor; and

**14.18.8.2.16.** Fluid level sensor.

**14.18.8.3.** No modifications may be made to any chassis or aerodynamic part to accommodate sensor mounting or sensor target.

**14.18.8.4.** Any sensors listed above may be fitted to the Engine only with the Engine Manufacturer's approval.

**14.18.8.5.** Entrants may relocate the rear laser, only if the laser remains inside the bodywork and rear end cover (IR-1203A009). The location and mounting must be submitted on IRIS for INDYCAR approval.

#### **14.18.9. Weight Jacker**

**14.18.9.1.** The weight jacker position can only be controlled by the Driver.

#### **14.18.10. Track Condition Radio (TCR)**

**14.18.10.1.** The TCR and antenna must be mounted in the INDYCAR-specified location.

**14.18.10.2.** The TCR dash light must be mounted in the INDYCAR-specified location.

**14.18.10.2.1.** A minimum of two (2) TCR steering wheel lights must activate simultaneously with the TCR dash lights.

#### **14.18.11. Black Flag Indicator**

**14.18.11.1.** A black flag indicator (text, and/or light) must be included in the dash/steering wheel configuration.

**14.18.11.2.** INDYCAR triggers the black flag indicator through the timing transponder.



#### 14.18.12. Car Position Display

14.18.12.1. The LED Display Panel must be used as supplied and in the position specified by INDYCAR.

14.18.12.2. The Car Position Display panel must be connected and operational during all on-Track activities.

#### 14.18.13. Chassis and Engine Looms

14.18.13.1. Chassis and Engine looms must be used as supplied by Cosworth and the Engine Manufacturers.

#### 14.18.14. Push to Pass Parameters

14.18.14.1. The total Push to Pass time and time per push per Race are as follows:

	Event	Maximum Time Per Push	Total Time (Seconds)
Push To Pass Parameters	St. Petersburg	15	150
	COTA	20	200
	Barber	20	200
	Long Beach	20	200
	IMS Road Course	20	200
	Detroit	15	150
	Road America	20	200
	Toronto	20	200
	Mid-Ohio	20	200
	Portland	20	200
	Laguna Seca	15	150

14.18.15. Any attempt to reset *tOvertakeTotalRemainingMaxMandated* during a Race Event is not allowed.

14.18.16. An indicator to enable Push to Pass will be sent via CAN communication from the timing and scoring beacon on board the Car to the team data logger. This signal must be passed on to the ECU unmodified and uninterrupted during all Road and Street Course Events.

14.18.17. Race Starts and any Race Restart that occurs before the lap prior to the white flag or prior to three minutes remaining in a timed Race Event will have the Push to Pass system disabled and will be enabled for a given Car once that Car reaches the alternate Start/Finish line.

#### 14.19. Data Logging and Telemetry – Chassis and Engine

14.19.1. At any Event where Cosworth Live on Air telemetry is supported or at any Event where point-to-point telemetry is utilized, data must be transmitted via CAN or serial to INDYCAR according to the Cosworth LOA Bulletin:

14.19.2. At all Events, Engine Manufacturers are provided with a pre-Event bulletin with the required ECU software version and parameter values for the locked INDYCAR calibrations. The bulletin is provided no later than forty-eight (48) hours before the start of the practice session one (1) for a given Race Event or Open Test.

14.19.3. At all Events, Engine Manufacturers must log the channels as specified by INDYCAR in the pre-Event bulletin in the ECU on all Cars.

#### 14.20. Fuel

14.20.1. Fuel must be used as supplied by INDYCAR with no modification (e.g. removal or addition).

14.20.2. The addition of any performance-enhancing substance to the fuel, air, or fuel/air mixture is prohibited.

14.20.3. The fuel contained in the Car's fuel system must not be cooler than five (5) degrees Fahrenheit below ambient temperature.

14.20.4. Fuel allotments are as follows:

14.20.4.1. For Indianapolis 500<sup>®</sup> Mile Race and Superspeedway Races, the quantity of fuel allotted in the pit tank is equal to 4mpg for the Race distance. The Race distance includes parade and pace laps.

14.20.4.2. For Road/Street Courses/Short Oval Races, the quantity of fuel allotted in the pit tank is equal to 3mpg for the Race distance. The Race distance includes parade and pace laps.

14.20.4.3. For all Races, each Entrant may choose the quantity of fuel in the Car prior to entering Pit Lane for the Race.

14.20.4.4. For all Races, Entrants are not permitted to have their fuel hose hooked up to the Pit Lane tank when the Race allotment of fuel is dispensed into the tank. Entrants are not permitted to hook-up and flood the fuel hose until 1-hour prior to the "Grid the cars" call on the Team Broadcast Frequency.

14.20.5. Prior to Gridding, each Entrant will be permitted to plug in its fuel hose to top off its Car's fuel tank.

**14.20.6.** Portable containers are not permitted on Pit Lane.

**14.20.7.** Fuel may not be stored in the Entrant's garage.

**14.20.8.** NFPA (National Fire Protection Association), state and/or local code are a part of the Rules.

#### **14.21. Refueling**

**14.21.1.** The use of the MSE (MS1233) fuel probe sensor and system is mandatory.

**14.21.2.** All refueling nozzles and refueling receptacles must be returned to the manufacturer for servicing prior to the Entrant's first Race, Indianapolis 500<sup>®</sup> Mile Race, and Pocono Race.

**14.21.3.** During a Race, all refueling must be performed by the INDYCAR-approved dry-break disconnect system. During refueling, only the fuel hose and vent hose can be attached to the fueling system. The fuel flow must be gravity-flow only and the vent hose must not have any evacuation assist devices attached.

**14.21.3.1.** The refueling coupling must be used as supplied by Red Head Valves - Model VF 1100 M-3 fuel probe with Red Head Valves Model VF 1100 F-3 receiver.

**14.21.3.2.** All refueling hoses must be used as supplied by the Salem Republic Rubber Company (part #P7310-7F-A1298-030-1050GG). Refueling hoses must have a minimum length of ten (10) feet.

**14.21.3.3.** Fuel hose supports may not be longer than forty-eight (48) inches and must be approved by INDYCAR prior to use.

**14.21.3.4.** The inside diameter of all refueling hoses, fittings and connectors shall not exceed three (3) inches.

**14.21.4.** Only Dallara supplied fuel cell and vent systems may be used.

**14.21.5.** Entrants may be required to demonstrate the performance of all system parts prior to use. All refueling probes and fuel hoses must be inspected and sealed by INDYCAR before being placed on fuel storage tanks prior to each on-Track Event.

**14.21.6.** Practice Fueling

**14.21.6.1.** A single hose with a maximum outside diameter of 1.500 inches incorporating an approved self-closing valve at the tank end must be used.

**14.21.6.2.** Fuel may only be added through the dry-break vent system. The Engine must be shut off during any practice refueling. A crewmember must operate fire equipment during any refueling.

## 15. TIRES

### 15.1. General

15.1.1. Only Tires supplied by Firestone and approved by INDYCAR may be used. Each Tire must be used in its specified location.

15.1.1.1.1. Schrader valves must be used as supplied by Firestone.

15.1.1.1.2. Valve caps must be used during all on-Track activity and must provide an air-tight seal.

15.1.2. Tires are assigned to a specific Entrant. Tires may not be sold, traded or otherwise reassigned, given or transferred to any other Entrant.

15.1.3. Tires may not be changed on a Car once the Car is in its position in the Starting Lineup on the Grid without INDYCAR approval.

15.1.4. Tire warmers are not allowed.

15.1.5. No substance may be applied to the Tires.

15.1.6. Only nitrogen or compressed air may be used to inflate Tires.

15.1.7. An Entrant may only possess the following Tires:

15.1.7.1. tow Tires,

15.1.7.2. set-up Tires,

15.1.7.3. rig testing Tires, and

15.1.7.4. two (2) sets of wet Tires.

15.1.8. All other Tires must be returned to Firestone immediately following an on-Track Event. Unreturned Tires are subtracted from the Entrant's allotment at the following Event.

### 15.2. Tire Allotments

15.2.1. Each Entrant is allowed the following:

	Event Venue	Primary	Alternate	Rookie Driver
Tire Allotments	St. Petersburg	7	4	1
	COTA	7	4	1
	Barber	7	4	1
	Long Beach	7	4	1
	Indianapolis RC	7	4	1
	Indianapolis 500®	36	0	0
	Detroit	9	4	1
	Texas	<del>13</del> 14	0	0
	Road America	8	4	1
	Toronto	7	4	1
	Iowa	<del>11</del> 10	0	0
	Mid-Ohio	7	4	1
	Pocono	<del>13</del> 12	0	0
	Gateway	11	0	0
	Portland	7	4	1
	Laguna Seca	7	4	1
	COTA Open Test	<del>7</del> 8	0	1
	Indianapolis 500® Open Test	4	0	0
	Indianapolis 500® ROP	3	0	0
	Indianapolis 500® Refresher	2	0	0
Indianapolis 500® Fast Nine*	2	0	0	
Laguna Seca Open Test	4	0	1	

\* Each Entrant qualifying for the Fast Nine will be allotted two set of tires for use Sunday, May 19. One set to be used only during the Fast Nine morning practice session. The second set to be used during Fast Nine Qualifications.

**15.2.2.** Single Event Race Weekends: A maximum of five (5) sets of wet Tires [including two (2) sets transported by the Entrant].

**15.2.3.** Double-Header Race Location: A maximum of seven (7) sets of wet Tires [including two (2) sets transported by the Entrant].

### **15.3. Road Course/Street Course Tires**

#### **15.3.1. Rookie Drivers**

**15.3.1.1.1.** Rookie Drivers may purchase one (1) additional set of Tires for use during practice session one (1). If purchased, the additional set of Tires is returned at the completion of practice session one (1).

#### **15.3.2. Practice/Returning Tires**

**15.3.2.1.** At the completion of practice session one (1), Entrants must return one (1) set of either primary or alternate Tires.

**15.3.2.2.** At the completion of practice session two (2), Entrants must return one (1) set of Tires and they must be the opposite compound (primary/alternative) of Tires returned at the completion of practice session one (1).

#### **15.3.3. Race Tires**

**15.3.3.1.** Within thirty (30) minutes of the completion of the practice/Qualifications session prior to the Race, an Entrant must notify INDYCAR via IM to the tire declaration account the Tire Compound it will use for the Race start.

**15.3.3.1.1.** Failure of an Entrant to submit the required notice will result in INDYCAR assigning the Entrant the Tire Compound chosen by fewer Entrants.

**15.3.3.2.** A Car must complete two (2) laps on each Tire Compound.

**15.3.3.2.1.** Single Races: One (1) set of new (sticker) alternate Tires and one (1) set of primary Tires must be used.

**15.3.3.2.2.** Double-Header Races: One (1) set of alternate Tires and one (1) set of primary Tires must be used.

**15.3.3.2.3.** One (1) lap must begin once the Green Flag has been displayed to the Race Leader as decided by INDYCAR.

**15.3.3.2.4.** The second (2nd) lap may be completed in Pit Lane, even if the Car's Pit Box is prior the Start Finish Line.

**15.3.3.2.5.** Any Car failing to comply with this Rule shall receive a minimum one (1) lap penalty.

**15.3.3.2.6.** If a Car has Tire damage due to contact, the two (2) lap requirement for that Tire Compound will be considered fulfilled.

**15.3.3.2.7.** This Rule does not apply if INDYCAR declares a wet start or wet condition and/or three (3) or more Cars from different Entrants use wet Tires after the start of the Race.

#### **15.3.4. Wet Tires**

##### **15.3.4.1. Practice:**

**15.3.4.1.1.** Wet Tires may only be used when wet conditions exist.

##### **15.3.4.2. Qualifications:**

**15.3.4.2.1.** Wet Tires may only be used when wet conditions exist.

##### **15.3.4.3. Race:**

**15.3.4.3.1.** If INDYCAR declares a wet start, Cars must complete one (1) official lap on wet Tires which must start under a Green Flag. The lap may be completed in Pit Lane even if the Car is pitted before the Start/Finish Line.

### **15.4. Oval Events**

**15.4.1.** Entrants may start a Race on any of its allotted Tires.

### **15.5. Replacement Tires**

**15.5.1.** The Event replacement tire allotment is ~~ten (10)~~ eight (8) tires for the Racing Season:

**15.5.1.1.** Primary: ~~2~~ 1 tire (max) per Race Location

**15.5.1.2.** Alternate: 1 tire (max) per Race Location (~~5~~ 4 for season)

**15.5.1.3.** A replacement tire will only be allotted when the tire being replaced is returned to the Tire Mounting Area.

**15.5.1.4.** Allotment tires requested during Qualifications must be approved by INDYCAR prior to the tire being mounted.

**15.5.1.5.** ~~Replacement Allotment~~ tires are only available during INDYCAR-sanctioned Races ~~and Tests~~.

~~**15.5.1.5.1.** Replacement tires requested during Open Tests are subject to availability and must be approved by INDYCAR.~~

**15.5.2.** Unused replacement Tires returned to the Tire mounting area will not be credited back to the Entrant's annual allotment.

## 16. ENGINE SPORTING REGULATIONS

### 16.1. Installation Requirements

- 16.1.1. Only the Engine supplied by the Engine Manufacturer or its designee and approved by INDYCAR may be used during an on-Track Event. No modifications are allowed.
- 16.1.2. INDYCAR will seal all Engines prior to installation in the Car. No Car may participate in any on-Track activities during an on-Track Event without the INDYCAR Engine seals in place. Engine seals may not be broken, tampered with, or removed without the approval of INDYCAR.
- 16.1.3. An INDYCAR-approved air filter must be used as supplied in the specific location.
- 16.1.4. Only lubricants approved by INDYCAR and the Engine Manufacturer may be used.
- 16.1.5. No additives may be mixed with an INDYCAR-regulated fluid without prior INDYCAR approval.
- 16.1.6. Clutch assembly CP8153-DE03-SN carbon plate with steel housing is the only approved clutch. Only the following clutch assemblies are approved:
- AP - CP8153-DE03-SN
  - ZF - 883082002617
- 16.1.7. The bellhousing must be used as supplied by Dallara.
- 16.1.8. Entrants required to use the INDYCAR supplied torque shaft must maintain a shaft temperature of less than 125° C. Failure to comply with this Rule will require replacement of INDYCAR equipment at Entrant's expense.
- 16.1.9. Any heat shields or cooling ducts installed on the Car must not block visual access to the serial numbers on INDYCAR-supplied electronics, the Manufacturer parts, the turbocharger, or the INDYCAR Engine seals.
- 16.1.10. Only the Homologated exhaust system may be used. Exhausts and exit locations must remain as specified by Dallara or as Homologated. Exhaust/waste-gate pipes must protrude a minimum of 0.250 inches and a maximum of 1.000 inch through the bodywork. The exhaust opening in the sidepod must remain as Homologated with a tolerance of plus or minus 0.500 inches.
- 16.1.11. All Homologated parts provided by the Engine Manufacturer must be installed and used as supplied without modification.

### 16.2. Number of Engines and Engine Management

- 16.2.1. An Entrant may only possess one (1) Engine unless otherwise approved by INDYCAR.
- 16.2.1.1. An Entrant may not have more than two (2) Engines assigned to them at any one time.
- 16.2.1.2. If an Entrant is assigned two (2) Engines, the Engine that is not installed (waiting) must always be ready to be installed. If circumstances require the waiting Engine to be installed (i.e. crash or Engine failure) and it is not available, it will be considered to be an Unapproved Change-Out of the waiting Engine and a new Engine will be assigned to the Entrant.
- 16.2.2. Engine Pool – The Engine Manufacturer is responsible for Engine use planning; however, INDYCAR is responsible for all Engine assignments and will randomly assign Engines to each Entrant from an Engine Pool nominated by the Engine Manufacturer. Each Engine assignment increases the Engine Count for an Entrant by one (1).
- 16.2.2.1. A new Engine Pool and an Engine use plan must be submitted to INDYCAR prior to each on-Track Event by noon (local time of the Event) the Day prior to on-Track activities.
- 16.2.2.2. The Engine Pool for the Indianapolis 500® Race must be specified by the completion of Qualifications.
- 16.2.2.3. If a new Engine Pool is not specified, the Engine Pool from the previous on-Track Event will carry over.
- 16.2.2.4. All Engines will be assigned from a single pool of Engines with the exception of the Indianapolis 500® Race Event, which allows for one (1) additional Engine Pool to be specified to Entrants participating in the Short Indianapolis 500® Engine Program and Full Indianapolis 500® Engine Program.
- 16.2.2.5. All Engines presented in any Engine Pool must contain parts Homologated by INDYCAR and applied according to the Rules stipulated in the Engine Regulations.
- 16.2.2.6. If an Engine is used on-Track that is not from an on-Track Event's Engine Pool, it will be considered an Unapproved Engine Change Out.
- 16.2.2.7. An Engine Manufacturer must supply an Engine Pool of sufficient size to assign engines. The following guidelines must be followed:
- a) Engine Pool must exceed the number of cars needing an engine by at least 1 if that number is less than half the number of cars supported.
  - b) Engine Pool must at least match the number of cars needing an engine if that number is more than half the number of cars supported.
  - c) If the Engines available are not sufficient to supply cars, Engines will be assigned with a priority of crashed engine replacements followed by the next highest mileage Entrant engine. Entrants that cannot receive an assigned Engine due to lack of Engines in the pool must wait until the Engine Pool is nominated for the next event.

**16.2.3. Full Season Engine Program** – A Full Season Entrant is allowed four (4) fresh-built Engines from the Season Start of a given Racing Season until the Season Start of the following Racing Season. If circumstances require a fifth (5th) or more Engine is used, the following will apply:

**16.2.3.1.** A fifth (5<sup>th</sup>) or more Engine may be fresh or partially-used.

**16.2.3.2.** A fifth (5<sup>th</sup>) Engine is eligible to earn Engine Manufacturer points if a Full Season Entrant has completed the Full Season Entrant Engine Mileage with its first four (4) Engines. Otherwise, a fifth (5th) or more Engine does not earn Engine Manufacturer points.

**16.2.3.3.** Cars that are not eligible to earn Engine Manufacturer Championship Points are removed from the finishing order used for Race finish points in the Engine Manufacturer Championship.

**16.2.4. Short Indianapolis 500<sup>®</sup> Engine Program** – Short Indianapolis 500<sup>®</sup> Engine Programs will only be allocated one (1) Engine for the duration of the Indianapolis 500<sup>®</sup> Race Event.

**16.2.5. Full Indianapolis 500<sup>®</sup> Engine Program** – A Full Indianapolis 500<sup>®</sup> Engine Program has up to two (2) Engines for the duration of the Indianapolis 500<sup>®</sup> Race Event.

**16.2.6.** An Entrant participating in a Short or Full Indianapolis 500<sup>®</sup> Engine Program may start the Event with an Engine that is sealed prior to the Event with previous Engine miles since the Season Start. If that Engine reaches its Change Out Mileage prior to the Race, it may be changed according to [Rule 16.5.1](#). An Engine changed for this reason would not be considered an Entrant's Indianapolis 500<sup>®</sup> Race Engine unless specified as such by the Engine Manufacturer.

### 16.3. Engine Mileage

**16.3.1.** The Full Season Entrant Engine Mileage is 10,000 total miles for use in all Team Tests, Open Tests, and Race Events from the Season Start of a given Racing Season until the Season start of the following Racing Season.

**16.3.1.1.** A substitute Driver is the same Driver for purposes of Engine miles.

**16.3.2.** All Engine mileage must be reported to INDYCAR and is subtracted from the 10,000-mile allotment, regardless of Use. Mileage is decided from the official lap count from each on-Track Event multiplied by the official Track length. Race parade and pace laps, Oval Qualifications warm-up laps, and initial out lap from each practice and Qualifications session are included. The following will also apply:

**16.3.2.1.** For all tests where official timing and scoring is not available, the Engine Manufacturer must provide INDYCAR with Engine mileage within forty-eight (48) hours of the completion of a Test.

**16.3.2.2.** Where official timing and scoring is not available, mileage may be calculated by the ECU.

**16.3.2.3.** The Engine Manufacturer must provide INDYCAR with ECU and boost sensor serial numbers within forty-eight (48) hours of the completion of the Event for the purpose of tracking mileage.

**16.3.2.4.** An Engine's current total mileage is rounded to the nearest mile.

### 16.4. Engine Change-Out

**16.4.1.** Between the last Race of the Racing Season and the Season Start of the following Racing Season, an Entrant may change-out Engines as it deems appropriate without penalty and without the prior approval of INDYCAR.

**16.4.2.** From the Season Start until the completion of the Racing Season, no Engine may be changed-out without the prior [written](#) approval of INDYCAR and the Engine Manufacturer. Engine Change-Outs by an Entrant may be specified by INDYCAR as either:

- Approved Engine Change-Out, or
- Unapproved Engine Change-out.

**16.4.3.** Unless otherwise stated, any Engine that is assigned shall count as one (1) of the fresh-built Engines allotted to an Entrant.

### 16.5. Approved Engine Change-Outs

**16.5.1. Engine Retired** – An Engine that has reached an Engine Change-Out Mileage determined by the Engine Manufacturer may be changed out at any time. An Engine changed-out for this reason may not be reinstalled, is removed from the Engine Pool and will have its Engine seals removed.

**16.5.2. Team Test Allowance** – After the completion of a Race, an Entrant with an Engine installed that would exceed its Engine Change-Out Mileage during a Test may install a lower mileage Engine with INDYCAR approval for the purpose of participating in a Test scheduled between two (2) Races. In this case, the following will apply:

**16.5.2.1.** The higher mileage Engine from the previous Event must be installed to complete its planned life cycle prior to the start of the next Race Event, or be removed from service with the Engine seals cut. After the next Race Event, the higher mileage Engine will be considered to be Retired and must be Changed-Out according to [Rule 16.5.1](#). The remaining assigned Engine must then be installed to complete its scheduled life cycle.

**16.5.2.2.** An Entrant must first use Engines from its current allocation.

**16.5.2.3.** If an Entrant is currently allocated only one (1) Engine, a second, fresh Engine may be allocated to the Entrant for the purpose of participating in the Test.

**16.5.2.4.** Any Engine installed for the purpose of completing Testing remains allocated to the Entrant and must be installed after the first, higher mileage Engine has completed its life.

**16.5.3. Manufacturer Test Engine** – An Entrant participating in an INDYCAR, Tire or Engine Manufacturer Test may fit a Manufacturer Engine for that Test without penalty. Such Engine Change-Outs must comply with the Rules. Engine miles used for such Tests do not count against the Full Season Entrant Engine Mileage limit.

**16.5.4.** Indianapolis 500<sup>®</sup> Race Engine – For Entrants with multi-Engine programs, a fresh Engine may be fitted before the Indianapolis 500<sup>®</sup> Race without penalty, subject to availability and the following conditions:

**16.5.4.1.** Both Engines remain allocated to the Entrant, and both Engines must reach their Change-Out Mileage before any other Engines are allocated to the Entrant.

**16.5.4.2.** After the completion of the Indianapolis 500<sup>®</sup> Race Event, an Entrant may choose either of these allocated Engines to be installed; however, the installed Engine must remain in the Car until it reaches its Change-Out Mileage.

**16.5.5.** Once an Indianapolis 500<sup>®</sup> Engine is fitted to the Car, removal of the Engine prior to the Indianapolis 500<sup>®</sup> Race is an Unapproved Engine Change-Out.

**16.5.6.** Special/Non-Race Events

**16.5.6.1.** A Manufacturer Engine may also be used for specific Special/Non-Race Events with prior approval from INDYCAR.

**16.5.6.2.** Pit Stop Competition – For the pit stop competition held on Carburetion Day of the Indianapolis 500<sup>®</sup> Race Event, Engine Manufacturers may substitute any Engines for assigned Engines with INDYCAR approval.

**16.5.7.** Operating Outside Guidelines – Changing an Engine before the Change-Out Mileage because it has been operated outside of the Engine Manufacturer's guidelines are subject to the following:

**16.5.7.1.** Entrant pays the repair costs of the Engine including parts, labor, shipping and travel costs for INDYCAR personnel; and

**16.5.7.2.** Once the Entrant pays the Engine Manufacturer the repair costs, the Entrant will be credited the unused mileage of the Engine and be supplied a fresh or used replacement Engine from the Engine Pool.

**16.5.8.** Crash Damage – An Engine that has suffered crash damage requiring a Non-Minor Repair may be changed without an Unapproved Engine Change-Out penalty only if the following conditions are met:

**16.5.8.1.** The Engine Manufacturer presents evidence of crash damage to INDYCAR;

**16.5.8.2.** Only parts failed as a result of the crash are replaced;

**16.5.8.3.** INDYCAR approves the change and assigns the Entrant a fresh Engine from the pool (only if an Engine is not already assigned to the Entrant); and

**16.5.8.4.** The crashed Engine remains allocated to the Entrant and must be returned when the repair is complete to finish its life before another Engine is allocated.

## **16.6. Unapproved Engine Change-Outs**

**16.6.1.** Any Engine Change-Out that is not explicitly identified as an Approved Engine Change-Out is considered an Unapproved Engine Change-Out.

**16.6.1.1.** Any Engine that undergoes an Unapproved Engine Change-Out may not be reinstalled, is removed from the Engine Pool and will have its seals removed.

**16.6.2.** Entrant-Initiated Change-Out – For an Entrant-initiated Engine Change-Out, the Change-Out is considered a Rules violation and the Entrant will be listed in a position at the rear of the Starting Lineup for the next Race, regardless of whether the Change-Out occurs at a Race or Test Event.

**16.6.2.1.** If an Entrant makes two (2) Unapproved Engine Change-Outs during an on-Track Event, the penalty for the second (2nd) Unapproved Engine Change-Out is served at the following Race.

**16.6.2.2.** Entrant-initiated Engine Change-Outs lose ten (10) Driver and Entrant points.

**16.6.2.3.** All mileage remaining on an Engine prior to the Unapproved Engine Change-Out is lost.

**16.6.2.4.** No Engine Change-Out Starting Lineup penalties are served during the Indianapolis 500<sup>®</sup>; however, points penalties will be applied. Penalties carried over into or earned at the Indianapolis 500<sup>®</sup> are served at subsequent Races.

**16.6.2.5.** Entrants not participating in consecutive on-Track Events do not carry-over any Engine Change-Out penalties.

**16.6.3.** Entrant Abuse – An Engine may be damaged by the actions of the Entrant including but not limited to the use of non-approved fuels or oils, tampering with the boost control or rev limit functions, continuing to operate the Engine after being informed that a problem has occurred including overheating ("Entrant Abuse"). Changing an Engine before the Change-Out Mileage for Entrant Abuse is subject to the following:

**16.6.3.1.** Entrant pays repairs costs for the Engine including parts, labor, shipping, and travel costs for INDYCAR personnel.

**16.6.3.2.** All mileage remaining on the Engine prior to the Entrant Abuse incident is lost.

**16.6.4.** Removing the Engine to test a Down on Power ("DOP") claim is an Unapproved Engine Change-Out.

## 16.7. Down on Power Engines

- 16.7.1. Entrant Claim** – An Entrant claiming an Engine is DOP must provide supporting data to the Engine Manufacturer before the claim is reviewed. The Engine Manufacturer may decide if the DOP claim is valid.
- 16.7.2. Limitation** – A DOP claim may not be made after the completion of the next-to-last (penultimate) Race Event of the Racing Season.
- 16.7.3. On-Track Torque Measurement** – An Entrant may request to install an INDYCAR-specified torque measurement shaft to determine whether it is down on power relative to other Engines provided by the Engine Manufacturer. If an Entrant's request is approved by INDYCAR the following applies:
- 16.7.3.1.** The Entrant must put up a bond of \$3,000 USD.
  - 16.7.3.2.** If an Entrant already has a shaft installed and they are part of a multi-car Team, another Team Member's car must install the torque shaft.
  - 16.7.3.3.** INDYCAR will compare the Entrant's torque values against the output of other instrumented Entrants running the same Engine Manufacturer's Engine and will assert whether the DOP claim is valid. No actual torque values will be shared with the Entrant or the Engine Manufacturer, only relative differences.
  - 16.7.3.4.** If the measurement does not show that the Engine is DOP beyond 2% of the average Engine power from all the Engine Manufacturers currently installed engines with torque measurement, the Entrant forfeits the bond.
  - 16.7.3.5.** If the measurement does show that the Engine is DOP beyond 2% of the average Engine power from all the Engine Manufacturers currently installed engines, the Entrant will be paid back the bond and the Engine Manufacturer will be charged \$3,000 USD for the use of torque measurement shaft.
  - 16.7.3.6.** Regardless of the outcome of this measurement, the rest of [Rule 16.7](#) still applies.
- 16.7.4. Manufacturer Agrees with Claim** – If the Engine Manufacturer accepts the DOP claim, the Engine Manufacturer informs INDYCAR of the issue. INDYCAR inspects the supporting data and in its discretion, decides if the DOP claim is valid. If it is decided by all parties that the Engine is DOP, INDYCAR shall:
- 16.7.4.1.** Approve the Engine Change-Out; and
  - 16.7.4.2.** Assign the Entrant a fresh or used Engine from the Engine Pool for the outstanding miles of the DOP Engine. For Engine mileage purposes, the reworked or rebuilt Engine will count as a substitute for the DOP Engine.
  - 16.7.4.3.** The DOP Engine will be considered to have met its full Engine life cycle, be removed from the Engine Pool and may not be reinstalled.
- 16.7.5. Manufacturer Disagrees with Claim** – If an Engine Manufacturer or INDYCAR does not accept that a DOP claim is valid, the Entrant making the claim may, in its discretion, pay the DOP bond to INDYCAR to have the Engine removed from the Car and retested by the Engine Manufacturer.
- 16.7.5.1. DOP Bond:**
    - 16.7.5.1.1.** For all Entrants, each DOP claim bond is \$50,000 USD.
    - 16.7.5.2.** INDYCAR will keep the DOP bond until an Engine power test is completed at the Engine Manufacturer's venue. The retest of the Engine must be completed within fifteen (15) Business Days of the DOP claim. INDYCAR reserves the right to have an Official present at the test.
- 16.7.6. DOP Engine Passes Retest** – If the DOP Engine retests within two (2) percent of its shipping test performance between 9,000 and 12,000 rpm:
- 16.7.6.1.** The Entrant loses the DOP bond and INDYCAR pays the DOP bond to the Engine Manufacturer;
  - 16.7.6.2.** The Entrant pays INDYCAR's costs for having an Official present at the test;
  - 16.7.6.3.** The DOP Engine is returned to the Entrant and installed prior to the next on-Track activity following the DOP test;
  - 16.7.6.4.** The DOP Engine is not an Unapproved Engine Change-Out;
  - 16.7.6.5.** The rebuilt or reworked Engine that was in the Car during the DOP claim test is assigned to the specific Entrant and must be used once the DOP Engine has completed its life cycle.
  - 16.7.6.6.** The Entrant loses ten (10) Driver and Entrant points; and
  - 16.7.6.7.** The Entrant will start the next Race from the rear of the Starting Lineup. No Engine Change-Out penalties will be served during the Indianapolis 500<sup>®</sup>, but points penalties will be applied. Penalties carried over into or earned at the Indianapolis 500<sup>®</sup> will be served at subsequent Races.
- 16.7.7. DOP Engine Fails Retest** – If the Engine retests more than two (2) percent under its shipping test performance between 9,000 and 12,000 rpm:
- 16.7.7.1.** INDYCAR returns the DOP bond to the Entrant;
  - 16.7.7.2.** The DOP bond does not increase the next time the Entrant makes a claim;
  - 16.7.7.3.** The Engine Manufacturer pays INDYCAR's costs for having an Official present at the test;
  - 16.7.7.4.** The Engine Manufacturer supplies the Entrant with an Engine from the Engine Pool for the outstanding miles of the DOP Engine. For Engine mileage purposes, the replacement Engine counts as a substitute for the Engine that was removed.



## **16.8. Engine Repair**

**16.8.1.** All Engine repairs during an on-Track Event must have prior approval from INDYCAR.

**16.8.2.** Minor Repair – A Minor Repair is a repair that can be done without the removal of either the cam cover and/or removal of any INDYCAR-applied seals.

**16.8.3.** An Engine that requires a Minor Repair, may, with INDYCAR's approval, be removed from the Car for repair without penalty. Use of the Car on-Track with another Engine is an Engine Change-Out.

**16.8.4.** If any of the INDYCAR-applied Engine seals needs to be broken or removed, the repair cannot be carried out unless an Official is present and INDYCAR gives prior approval. If the repair is carried out at the Engine Manufacturer's shop, the Engine Manufacturer pays reasonable pre-approved travel expenses for the Official to be present.

**16.8.5.** Non-Minor Repair – A Non-Minor Repair is a repair that requires the removal of the cam cover and/or removal of any INDYCAR-applied seals. Non-Minor repairs are only allowed to fix Engines that have suffered crash damage and the following must apply:

**16.8.5.1.** The Engine Manufacturer provides evidence of damage to INDYCAR;

**16.8.5.2.** Only one (1) Non-Minor Repair may be carried out on any given Engine during its 2500 life.

**16.8.6.** Part Replacement – Parts may only be replaced with parts of the same design as those removed or with INDYCAR-approved upgrades.

**16.8.6.1.** If a Non-Minor Repair requires replacement of the Engine cylinder block casting or cylinder head casting (not including respective covers), it is not repairable and is an Unapproved Engine Change-Out.

**16.8.7.** Repair Dyno Confirmation – The Engine Manufacturer may run the Engine at its testing facility for the purpose of assuring the Minor Repair is effective. The Engine must be returned to the Entrant before the next scheduled on-Track use of the Car unless it is superseded by another Approved Engine Change-Out.

**16.8.8.** Repair Completion – An Engine Manufacturer has three (3) weeks or before the final Race of the Racing Season (whichever comes first) to complete a Non-Minor Repair on an Engine and return it to an Entrant to be installed. If an Engine cannot be returned, the Engine Change-Out will be an Unapproved Engine Change. Any Engine that was assigned to an Entrant during the Non-Minor Repair remains assigned to the Entrant and must complete its mileage before additional Engines are assigned.

## **16.9. Partial Season Entrants**

**16.9.1.** Engine Manufacturers will support Partial Season Entrants approved by INDYCAR. Each Partial Season Entrant may use only the Engine supplied by the Engine Manufacturer or its designee and assigned by INDYCAR to the specific Entrant.

**16.9.2.** A Partial Season Entrant is not entitled to a fresh or zero (0) mileage Engine.

## **16.10. Engine Inspection**

**16.10.1.** INDYCAR may request an Engine inspection be carried out on an Entrant's installed Engine after on-Track activities. If the Engine must be removed from the Car, a new Engine is supplied from the Engine Pool. The inspected Engine returns to the Car within twenty-eight (28) calendar days to complete its remaining mileage.

**16.10.2.** INDYCAR does not pay rebuild costs incurred during any inspection of an Engine or its related parts and subsystems.

## 17. EQUIPMENT & GARAGES

### 17.1. Fuel Storage Tanks

- 17.1.1.** Refueling supply must be gravity flow only. The use of pressurization or vacuum during refueling is not permitted. All tanks are limited to a single outlet with a maximum inside diameter of 3.000 inches. The outlet can have a maximum 1.500-inch radius from the tank's external face to the outlet. The maximum length of the outlet including any attachments is limited to 11.000 inches from the front face of the tank.
- 17.1.2.** All tanks must be vented to atmosphere at all times using a Protectoseal 3.000-inch flame arrester/vent or equivalent.
- 17.1.3.** All tanks must use a spring-loaded valve between the tank flange and vent pipe. The following valves are permitted:
- Betts Model WD-305;
  - J.C. Carter Model JC-64075; and
  - Equivalent INDYCAR-approved model.
- 17.1.4.** Between the tank outlet and refueling hose, the following valves are permitted:
- Dan Jones Model 06-DJ or J.C. Carter valves: These valves are permitted one (1) splitter with a maximum thickness of 0.300 inches and a maximum length of 3.500 inches. The splitter may be horizontal or vertical, must be mounted in the tank flange and may not protrude into the tank;
  - Betts valve: This valve is not permitted a splitter. Entrants may not alter the vent or spring-loaded closing valve; and
  - Equivalent INDYCAR-approved model.
- 17.1.5.** All refueling tanks must have a manual air-operated emergency shut-off valve to the probe.
- 17.1.6.** No part of the refueling storage tank may be closer than 30.000 inches to the front face of the pit wall. The refueling storage tank outlet must be positioned between the center and 18.000 inches rearward of the center in the assigned pit and be square to the pit wall.
- 17.1.7.** All fuel level sight tubes must have a positive shut-off valve at both ends.
- 17.1.8.** All equipment must comply with the Rules of INDYCAR and where applicable the NFPA (National Fire Protection Association), state and/or local codes.
- 17.1.9.** Refueling tanks and probe must be grounded by an INDYCAR-approved method.
- 17.1.10.** Tank Capacities and Dimensions: Refueling tanks must be built to INDYCAR specifications (See illustrations below). Refueling tanks must be a single container made of T304 stainless steel or the equivalent and have a capacity of 152.00 U.S. Gallons. All dimensions are overall measurements with the top surface level. The maximum height of the refueling tank shall be 84.000 inches to the top surface, which must be level. The vent pipe shall be a minimum of 102.000 inches in height. All refueling tank height measurements will be made from the Pit Lane surface. No modifications may be made to the refueling tank specifications. Drawings for fuel tank are available from the INDYCAR office. All dimensions are in inches.
- 17.1.11.** Vinyl wrap, acrylic or water-based paint are the only types of finishes permitted on the outside of refueling tank.
- 17.1.11.1.** Coatings or coverings designed to provide an insulating R-value are not permitted.
  - 17.1.11.2.** Coatings or covering are not permitted inside of refueling tank.
- 17.1.12.** Cooling of the refueling tank or fuel in the refueling tank is not permitted. Any means to alter the difference of the internal temperature of the tank or fuel to the ambient external temperature is not permitted.
- 17.1.13.** Devices which alter the gravitational flow of fuel are not permitted, except as in [Rule 14.21.3.3](#).
- 17.1.14.** All support legs and height-adjusting devices used with the refueling tank must be approved by INDYCAR prior to use. Tank support legs must include feet with adequate area so that the tank, with fuel, will not sink into the pit surface. Metal or wood may be used under the support legs to distribute the load, provided it is not stacked in a hazardous manner. All tanks must include a mechanism approved by INDYCAR by which the tank may be moved away from the pit wall quickly and easily. Any wheels or castors attached to the tank support stand must be raised from contact with the pit surface.
- 17.1.15.** The same specification of tank will be used at all Events.

## Fuel Tank Specifications

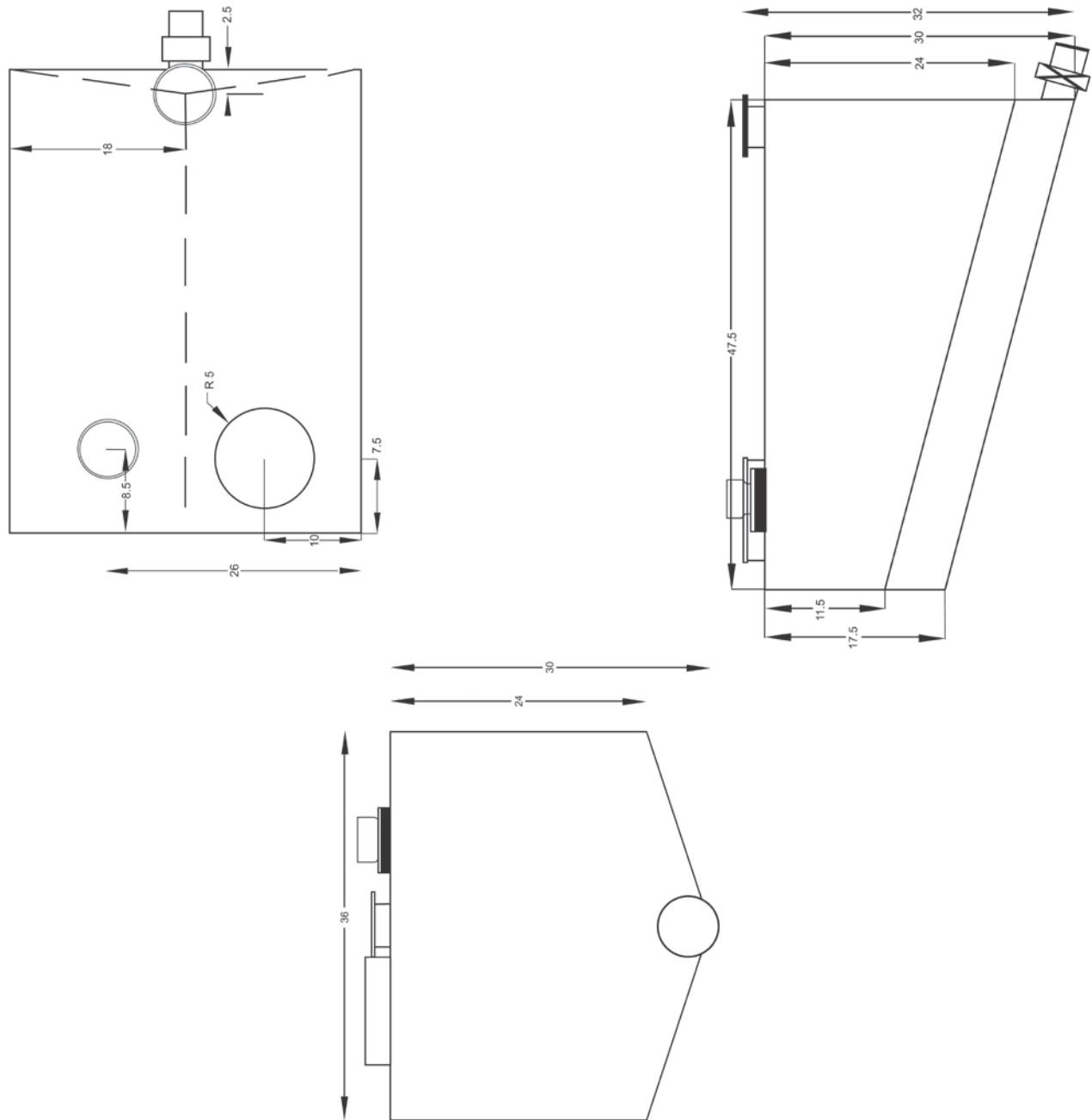

### 17.2. Pit Lane Fire Equipment

17.2.1. The Entrant must have a fully charged ten (10) pound water fire extinguisher in the Car's pit area. A gauge must be attached to each fire extinguisher. The mixture must contain ten percent (10%) Coldfire ~~and be equipped with Atomizing Nozzle (part # CFSE6HATOM, Cold Fire Southeast).~~

17.2.2. Each Entrant must have a minimum of two (2) open containers of water in the Entrant's pit area each with a capacity of five (5) gallons.

17.2.3. Each Entrant must have a two (2) pound dry chemical extinguisher in the Entrant's pit area.

### 17.3. Equipment

17.3.1. All equipment must remain inside the Entrants designated Pit Box on the cold side of the pit wall and the fire lane must remain clear at all times.

17.3.2. All nitrogen bottles must be kept securely fastened in all locations, including common storage areas, and have a cage device or other container approved by INDYCAR to protect all valves and regulators. All nitrogen bottles must be returned to the designated location and secured at the conclusion of each on-Track Event.

**17.3.3.** The maximum height of the scoring stand is 84.000 inches measured from the ground to the top of the stand excluding awning. The maximum surface area of an awning is 85 square feet in plan view and be no more than 120.000 inches in height measured from the ground. INDYCAR may determine if an Entrant may use an awning at a particular facility. Scoring stands using wheels or castors must be chocked or secured from moving and awnings, flags, umbrellas or shields may be used, provided they do not block spectator viewing.

**17.3.4.** Paint or other permanent markings may not be used in the garage, on the Pit Lane surface or on the pit wall.

**17.3.5.** Camera booms cannot extend more than 80.000 inches into Pit Lane and must be approved by INDYCAR.

**17.3.6.** Where permitted an Entrant may display one flag in its Pit Box, provided the flag is located behind the front face of the pit wall, is a maximum size of 5 ½ feet wide and 3 ½ feet high and a maximum height of 14 feet off of the pit floor.

#### **17.4. Garage**

**17.4.1.** INDYCAR reserves the right to assign transporter parking, garages and Pit Boxes.

**17.4.2.** If garages are available, Entries may receive one (1) garage per Entry.

**17.4.2.1.** Each Entry will receive a minimum space of 12 feet in width for truck parking.

**17.4.3.** If available, Manufacturers may receive a designated amount of space in the garage area.

**17.4.4.** If garages are not available, each Entrant shall receive a maximum 30 feet wide parking location in the garage area to use as a garage for the transporter and tent/awning, unless otherwise noted.

**17.4.5.** Entrant agrees to reimburse Event Promoter for the cost of repairing any damage to the garage area that occurs during occupancy by the Entrant.

**17.4.6.** Tents will not be permitted to extend beyond the rear of the trailer or front bumper of the tractor.

**17.4.7.** Entrants must submit a diagram of their tent and transporter footprint layout by November 15<sup>th</sup> of the year prior to the first event and seven (7) days prior for any subsequent changes for INDYCAR approval.

**17.4.8.** Tailgate safety cables are mandatory and must be approved by INDYCAR.

#### **17.5. Covers**

**17.5.1.** Teams are permitted to utilize wall systems within their garage or awning areas. If the wall system exceeds 36 inches in height, a diagram of the wall system must be submitted to INDYCAR via IRIS for prior approval. All wall systems must adhere to the following guidelines:

##### **17.5.1.1. Garages**

**17.5.1.1.1.** The wall system may only be placed at the front of the garage.

**17.5.1.1.2.** Support walls that sit 90 degrees to the front wall must not exceed four (4) feet in length.

**17.5.1.1.3.** Wall systems may not be used when there is a dedicated walkway down the center of the garage structure.

**17.5.1.1.4.** Wall systems must be removed at any time if requested by INDYCAR.

##### **17.5.1.2. Awning**

**17.5.1.2.1.** Wall systems may be used on all sides except the ends or sides where spectators are permitted.

**17.5.2.** During the entire Event, no screen, cover or other obstruction may be intentionally placed to obscure any part of a Car.

**17.5.3.** In addition to the above the following are specifically not permitted;

- a) Engine, gearbox or radiator covers while Engines are being changed or moved around the garage;
- b) Covers over spare wings;
- c) Parts such as (but not limited to) spare floors, fuel rigs or tool boxes may not be used as an intentional obstruction.

**17.5.4.** Rain covers may be used during inclement weather conditions. No other form of cover may be used.

**17.5.5.** Covers which are placed over damaged Cars or components are permitted.

## 18. SAFETY

### 18.1. Safety

**18.1.1. Safety Policy** - While INDYCAR seeks to maintain safe conditions for Competitors and others taking into account all aspects of the Event, Members recognize that conditions may not be safe and can be affected by human error. At any Event, each Member acknowledges and agrees that racing is a hazardous activity and each Member's involvement and/or participation is with expressed assumption of this risk.

**18.1.1.1.** While acknowledging the inherent risk of racing to Competitors and other Members involved and/or participating in an Event, Members are personally responsible for their own safety, for the safety of each Member of Member Group and for the safety of their racing equipment. No Event Promoter, INDYCAR, or any Manufacturer, or other Member is responsible for the adequacy of any Member's racing equipment or racing activity to accomplish this purpose. No Event Promoter, INDYCAR, or any Manufacturer or other Member makes any representation, express warranty, implied warranty or covenant that safety equipment and/or personnel will prevent or reduce the Member's risk or extent of injury in any Event.

**18.1.1.2.** INDYCAR may take any action including canceling, postponing, temporarily stopping or delaying an Event, if INDYCAR determines that basic safety requires such action. INDYCAR may order off the Track any Member or Car that INDYCAR determines constitutes a hazard. INDYCAR may, prohibit any Member or Member's equipment from entering or continuing in an Event. Except as provided in [Rule 10.2.1](#), none of such decisions during an Event may be reviewed and/or appealed. In the event a Driver is ordered off the Track due solely to driving performance, the Entrant may replace the Driver with a Driver approved by INDYCAR and continue in the Event pursuant to [Rule 4.3.3](#).

### 18.1.2. Medical/Rescue Requirements and Injury Reports

**18.1.2.1.** A Driver may be required to demonstrate ability to exit the Car to INDYCAR's satisfaction by a method as determined by INDYCAR.

**18.1.2.2.** A Driver involved in a crash or injured in an incident must report to the medical center or as directed by INDYCAR and may neither continue in the Event nor participate in future Events without clearance from INDYCAR.

**18.1.3. Biomedical Research and Device Testing Policy** – All Members must comply with INDYCAR's Biomedical Research and Device Testing Policy available from ePaddock.

**18.1.4. Safety Inspections** – INDYCAR may inspect any equipment prior to each Event and re-inspect equipment at any time including, without limitation, before, during or after each Event. An Entrant may be required to replace without limitation seats, seat belts, helmets, headrests, head restraint systems and other equipment at any time, as determined by INDYCAR.

### 18.1.5. Personal Safety Equipment

**18.1.5.1. Drivers** – All Drivers must wear:

- a) Fire resistant one-piece uniform conforming to SFI 3.2A/5 or FIA 8856-2000 specifications;
- b) Fire resistant socks;
- c) Fire resistant shoes;
- d) Fire resistant gloves;
- e) Nomex underwear long sleeve tops and full-length bottoms;
- f) Fire resistant head sock.

**18.1.5.1.1.** All removable dental appliances, chewing gum, rings, watches and other jewelry and comparable items should be removed before a Driver participates in any on-Track Event.

**18.1.5.1.2. Helmets** - All Drivers must wear safety helmets designed specifically for automobile racing that meet or exceed the FIA 8860-2010 or FIA 8860-2018 specification. Helmets must be spherical in shape and be fitted with a face shield that has an INDYCAR-approved positive latching mechanism designed to keep the shield down in the event of a crash. Aerodynamic devices must not protrude more than 0.250 inches from the surface outside of the shaded area shown below. Inside the shaded area, a 0.500-inch-high device is allowed. Flat back designs are not permitted. All helmets must be fitted with the INDYCAR approved removal system.



**18.1.5.1.2.1.** The visor shall be fitted with a reinforcement panel in accordance with the 2011 F1 VISOR REINFORCEMENT PANEL FOR FIA 8860 HELMET specification. The original visor, before the reinforcement panel is fitted, shall be certified with the helmet to FIA 8860-2010 or FIA 8860-2018 specification.

**18.1.5.1.3.** All helmets must be inspected and approved by INDYCAR before use and are subject to confiscation and re-inspection by INDYCAR at any time, including, without limitation, before, during or after each Event. INDYCAR shall affix stickers to the helmets signifying approval for use. At any time, including, without limitation before, during or after each Event, INDYCAR may remove the approval stickers and require the helmets to be re-inspected and refurbished by a certified helmet manufacturer before INDYCAR will consider them for re-approval. The helmet manufacturer must submit to INDYCAR documentation stating the refurbished helmet is approved for use in competition in accordance with the Rules.

**18.1.5.1.4.** Head Restraint Systems – INDYCAR requires the use of head restraint systems. Head restraint systems must meet or exceed FIA 8858-2010 certifications and be approved by INDYCAR.

**18.1.5.1.4.1.** All head restraint systems must be inspected and approved by INDYCAR before use and are subject to confiscation and re-inspection by INDYCAR at any time, including, without limitation, before, during or after each Event. INDYCAR shall affix approval stickers to each head restraint system signifying approval for use. At any time, including, without limitation before, during or after each Event, INDYCAR may remove the approval stickers and require the head restraint system to be re-inspected and refurbished by the FIA certified head restraint system manufacturer before INDYCAR will consider it for re-approval. The head restraint system manufacturer must submit to INDYCAR documentation stating that the head restraint system is approved by FIA for use in competition in accordance with the Rules.

**18.1.5.1.5.** Ear Pieces – All Drivers must wear INDYCAR-supplied instrumented earpieces. Earpieces must be presented to INDYCAR for testing before each Event and upon request. Repair and/or replacement of the earpieces may be at the Driver's expense.

**18.1.6.** INDYCAR may examine any Car involved in a crash and determine if it is suitable for further participation and all Members shall cooperate in the preparation of damage reports, photographs, videotaping and impact recording analysis. INDYCAR will inspect the items. Any item that does not successfully complete inspection must be repaired, re-certified or replaced by the Entrant at the Entrant's cost prior to use.

**18.1.7.** Chassis, nose and attenuator structural repairs may only be made by Dallara.

**18.1.8.** Chassis-repair forms must be submitted to INDYCAR for approval prior to the Car participating in the next Event.

**18.1.9.** After a crash, an Entrant must present the following items and any others to INDYCAR, upon request

- a) Driver's Helmet
- b) Driver's Head Restraint System
- c) Driver's Seat
- d) Chassis Headrest
- e) Steering Wheel
- f) Ear Pieces

**18.1.10.** Seating System

**18.1.10.1.** Each seat must be manufactured for a specific Driver. Each seat must have a unique identification tag from the seat manufacturer and be date stamped. All seats must be inspected and approved by INDYCAR before use and will be subject to re-inspection by INDYCAR at any time. INDYCAR may require a seat to be replaced.

**18.1.10.2.** The Driver's seat must conform to the Driver's anatomy and be constructed of an INDYCAR-approved material that will permit support and energy-attenuation both laterally and rearward. This material must fill as much of the cockpit under, behind and to the side of the Driver as possible. The seating system must be in place when the Car is inspected.

**18.1.10.3.** When the Driver is seated, there must be a smooth transition of energy-attenuating materials between the top of the seat and the cockpit rim padding, including the rear headrest. There must be no projections that could provide a fulcrum between the Driver's head and neck.

**18.1.11.** Seat Belts - An approved seat belt with an approved quick-release mechanism must be used. Both the fastening design and condition of the belt is subject to inspection by INDYCAR. Life of the belts in use shall not exceed five (5) years and must be date-stamped by the manufacturer. All belts must conform to the following SFI specifications: 3-inch SFI 16.1, 2-inch SFI 16.5, [FIA-8853/98](#), FIA 8853-2016 (6-point only), or equivalent specification as approved by INDYCAR.

**18.1.11.1.1.** Seat belts must be worn in such a manner that they are tight and pass around the pelvis at a point below the anterior superior iliac spine.

**18.1.11.1.2.** Seat belts may not pass over the sides of the seat. They must come through the seat at the bottom on each side thereby wrapping and holding the pelvis over the greatest possible area.

**18.1.11.1.3.** 6-point (crotch) belts must be connected to the main belt quick-release mechanism and securely attached to the chassis.

**18.1.11.1.4.** Seat belts which have had to withstand a crash in excess of fifty (50) Gs must be replaced.

**18.1.11.1.5.** Only the Dallara shoulder belt brackets (IR1201C001 Wide and IR1201C003 Narrow) and associated hardware may be used as supplied without modification.

**18.1.11.1.6.** Only the Dallara Lap Belt Mounting Plates (IR1201C002) and associated hardware may be used as supplied without modification.

**18.1.11.1.7.** Only the Dallara-recommended Anti-Submarine belts' mounting hardware may be used as supplied without modification.

**18.1.12.** Shoulder Harness – Two (2) over-the-shoulder straps must be used. HANS® specific double-shoulder belts are also permitted provided they are mounted and used according to manufacturer specifications. Both the fastening design and condition of the straps is

subject to inspection by INDYCAR. Life of the straps in use shall not exceed five (5) years and must be date-stamped by the manufacturer. Belts should be attached level with the top of the Driver's shoulders or at a slightly downward angle.

**18.1.12.1.** Mounting of all belts must use the manufacturer supplied mount and use the supplied mounting positions unless otherwise approved by INDYCAR.

**18.1.13.** Headrest -Headrests must be used as supplied by Dallara (Oval Events: IR1201B033, Road/Street Course Events: IR1201B032 or IR1201B033). Oval headrests (IR1201B033) may only be covered with decal.

**18.1.13.1.** All headrests must be inspected and approved by INDYCAR before use and will be subject to confiscation and re-inspection by Officials at any time. INDYCAR shall affix stickers to the headrests signifying approval for use. At any time, Officials may remove the approval stickers and require the headrests to be re-inspected and refurbished by Dallara before INDYCAR may consider them for re-approval.

**18.1.13.2.** Headrests must be attached by the Dallara supplied mechanism. The headrest must be in place during technical inspection.

**18.1.14.** Additional Headrest Padding – Additional side padding must not exceed the height of the stock headrest as viewed from the side. Additional rear padding must not exceed the height or width of the headrest as viewed from the front. All padding must be contained in the original headrest dimensions as looked at in plan view.

The additional headrest padding, if used, must consist of separate pieces; left side, right side and/or rear. The side pieces are restricted to 15.000 inches in overall length and must have a minimum 3.000-inch leading edge taper from the front edge when viewed from the top (plan view).

The additional padding must be removable independently of each other without the use of tools. All additional padding must be manufactured completely of foam, each piece may have a single layer Kevlar backing to assist in the mounting providing that it remains flexible and does not interfere with the original function of the stock headrest.

Any covering used on the additional padding must remain flexible and be approved by INDYCAR.

Additional padding may not be taped along any surface. All additional pads and coverings must be inspected and approved by INDYCAR prior to use.

**18.1.15.** Roll Hoop – The Drivers helmet must be a minimum of 7.000 inches below the chassis mounting face of the roll hoop camera.

**18.1.16.** Cockpit – Cars must have fitted all the Dallara supplied cockpit panels and EPP foam panels in the footbox, leg and seat area. No modifications can be made without prior INDYCAR approval.

**18.1.17.** The following steering wheel quick disconnects are approved:

	Manufacturer	Description	Part Number
Steering Wheel Quick Disconnects	Krontec	Stock Quick Disconnect	KR-QR-30-3B
	Cosworth (Krontec)	Cosworth 8STA Female QR Assy	31M-0012
	SPA	SPA tight tolerance Quick Disconnect	10-QR2-B T SP
	Dallara standard (SPA)	Dallara Standard Quick Disconnect	IR12100339

**18.1.18.** On-Board Fire Equipment – Each Car must have the Dallara supplied built-in operable fire extinguishing equipment with a minimum content of 2.250 liters in the Dallara/INDYCAR specified location. The U.S. Department of Transportation approved fire suppressant used must be AFFF-M-E fluid.

**18.1.19.** Impact Recorders – All Cars must make provisions for the installation of an impact recorder.

**18.1.19.1.** The impact recorder supplied by INDYCAR and used without modification, must be securely bolted using four (4) bolts to the main chassis structure in the Dallara/INDYCAR specified location.

**18.1.19.2.** The impact recorder download block and indicator lights must be located in the Dallara/INDYCAR specified location.

**18.1.20.** Crew Members and Other Competitors Participating in a Pit Stop – Over-the-wall crew members and any Member physically participating in the refueling process shall wear:

- a) Fire resistant uniforms conforming to SFI 3.2 A/1 specifications;
- b) Fire resistant shoes;
- c) Fire resistant gloves;
- d) Nomex underwear long sleeve tops and full-length bottoms;
- e) Fire resistant head sock (fueler and deadman);
- f) Fueler - Full-face helmet with fire-retardant Nomex lining (visor must remain down during fueling process);
  - Fueler helmet must be inspected by INDYCAR prior to the first Race Event of a Season and prior to the Indianapolis 500<sup>®</sup> Mile Race; and
- g) All other over-the-wall Competitors must use an INDYCAR-approved full-face helmet.

**18.1.20.1.** Crew Members, Other Competitors and Officials - Except as provided in [Rule 18.1.5.1](#) and [Rule 18.1.20](#) all Competitors and Officials on the trackside of Pit Lane must adhere to the following dress code:

- a) Long pants;
- b) Closed-toe shoes; and
- c) Shirts with sleeves (no tank tops).

**18.1.20.1.1.** This Rule does not apply to individuals in the pit area who are not Competitors or Officials or to any individuals in the garage area or non-restricted areas.

**18.1.20.1.2.** INDYCAR and/or an Event Promoter may have additional or different requirements for a particular Event.



## 19. GLOSSARY

- **ACCUS-FIA** – The Automobile Competition Committee of the United States is the ASN of FIA for the United States. ACCUS is comprised of the six (6) major motorsports sanctioning organizations (known by or within the FIA as "member clubs"): IMSA, INDYCAR, NASCAR, NHRA, SCCA and USAC. In accordance with the FIA statutes and the international sporting code, ACCUS-FIA has delegated its sporting power to the member clubs, except for FIA World Championship events.
- **Aero Kit** – All the components of the Car identified by INDYCAR, supplied by an Approved Supplier, approved by INDYCAR and governed by these Rules for all circuit configurations.
- **Approved Engine Change-Out** – An Engine Change –Out approved by INDYCAR and not subject to penalty.
- **Approved Supplier** – A supplier (including Manufacturers) of components that has been approved by INDYCAR, in its sole and absolute discretion.
- **ASN** – The National Sporting Authority of the FIA is a national automobile club or other national body recognized by the FIA as sole holder of sporting power in a country, except that in accordance with the FIA statutes and the international sporting code, an ASN may delegate some or all of its sporting power to its member clubs. An ASN is the liaison between its member clubs, other ASNs and the FIA. An ASN prepares listings on the international calendar, issues international motorsport licenses to its citizens and foreign citizens living in the country, issues authorizations for foreign participation and certifies and maintains domestic and international records.
- **Associate** – The firm(s), corporation(s) or other business association(s) named on an Associate's membership application approved by INDYCAR, remaining in Good Standing and uniquely identified by a tax identification number. Associate includes Associate and Associate's officers, directors, members, owners, successors, assigns, agents, employees, representatives and affiliates. Associate includes Manufacturers. Associate is responsible for Associate Group.
- **Associate Group** – Associate Participant, Associate Guest and each third-party Associate represents. "Associate Participant" is defined as any individual who is a Participant by reason of his or her relationship to Associate. "Associate Guest" is defined as any individual whose presence at a Track is at the invitation of the Associate.
- **Backup Car** – A spare Car an Entrant may use on-Track in place of a primary Car if approved by INDYCAR.
- **Blend Line** – The time line that decides the sequential order of Cars on-Track relative to Cars exiting Pit Lane under a Yellow Condition.
- **Business Day** – Any day other than a Saturday, Sunday or other day on which commercial banks are authorized to close under the laws of, or are in fact closed in, the state of Indiana.
- **Car** – A four (4) wheel automotive vehicle consisting of the combination of Aero Kit, Chassis, Engine, gearbox and Tires. The vehicle must be supplied by Manufacturers or Approved Suppliers, approved by INDYCAR and conform to the specifications, spirit and illustrations in and intent of, the Rules.
- **Competitor** – A Driver, Entrant, crew member, Manufacturer or any other individual or entity who is a Member and participates competitively in an Event.
- **Cosworth** – Cosworth, LLC, an approved electronic supplier. Any reference in the Rules to "Cosworth" is referring to Cosworth, LLC.
- **Current Indy Lights Series Driver** – A Driver that has participated in the current or the previous Indy Lights season and/or approved by INDYCAR.
- **Dallara** – Dallara, LLC, the approved chassis manufacturer. Any reference in the Rules to "Dallara" is referring to Dallara, LLC.
- **Day** – The twenty-four (24) hour period within a single calendar day.
- **Discretion** – The exercise by INDYCAR of judgment in making a determination as to the application, construction and interpretation of the Rules; and is required because of the need for decisions that depend upon immediacy without reflection and/or that are often subjective.
- **Double-Header Race Location** – A Race Location where more than one Race is held. Double-Header Race Location does not include the Indianapolis Motor Speedway.
- **Driver** – The individual named on a Driver's License and membership application approved by INDYCAR and issued by ACCUS-FIA (or another ASN, if applicable) and remaining in Good Standing. Driver is responsible for Driver Group.
- **Driver Group** – Driver Guest and each third-party Driver represents. The term "Driver Guest" shall mean and include any individual whose presence at an Event is at the Driver's invitation.
- **ECU** – The INDYCAR approved and supplied engine control unit (ECU), which is the primary device responsible for the control, monitoring and data logging of all Engine induction, fuel and turbo charger control sub-systems.
- **Engine** – An engine supplied by one of the engine Manufacturers or their designees, approved by INDYCAR and conforming to the specifications, spirit and illustrations in and intent of the Rules.
- **Engine Change-Out** – The replacement of an Entrant's Engine with another from the same Manufacturer.
- **Engine Change-Out Mileage** – A mileage determined by the Engine Manufacturer as to when an Engine may be able to be changed out. This mileage is not fixed, does not need to apply to all Engines.
- **Engine Count** – The total number of Engines assigned to an Entrant and installed in the Car during the Racing Season.
- **Engine Pool** – The Engines presented to INDYCAR by the Engine Manufacturers for random allocation to Entrants. Engines are still considered part of the Engine Pool once they have been allocated to Entrants until they have reached the approved Engine Change-Out mileage or until they are deemed failed and an Unapproved Engine Change Out has occurred.

- **Entrant** – The firm(s), corporation, or other business association(s) named on an Entrant's License and membership application approved by INDYCAR and issued by ACCUS-FIA, remaining in Good Standing and uniquely identified by a tax identification number and Car number. Entrant includes Entrant and Entrant's officers, directors, members, owners, successors, assigns, agents, employees, representatives and affiliates. Entrant is responsible for Entrant Group.
- **Entrant Group** – Entrant Participant, Entrant Guest and each third-party Entrant represents. "Entrant Participant" is defined as any individual who is a Participant by reason of his or her relationship to Entrant. "Entrant Guest" is defined as any individual whose presence at a Track is at the invitation of the Entrant.
- **Entry** – An Entrant's Car and Driver combination on an Entry form displaying the Entrant's Car number and approved by INDYCAR for participation in a designated on-Track Event.
- **Event** – Any racing, promotional and/or entertainment or other activities associated with, sanctioned by and/or organized in cooperation with INDYCAR or occurring at the site of, contemporaneously with or reasonably connected to said activities. Event does not include any Indy Lights® Series, Indy Pro 2000 Championship, USF2000 Championship and/or MX-5 Cup events, as those events are covered by separate Rules.
- **Event Agreement** – The agreement in effect between INDYCAR and an Event Promoter regarding the conduct of an Event and/or Events.
- **Event Promoter** – The firm(s), corporation(s) or other business association(s) named on an Event Agreement with INDYCAR and responsible for designated operations of an Event. Event Promoter includes Event Promoter and Event Promoter's officers, directors, members, owners, successors, assigns, agents, employees, representatives and affiliates.
- **FIA** – The Federation Internationale de l'Automobile.
- **Firestone** – Bridgestone Americas Tire Operations, LLC, is the approved Tire manufacturer. Any reference in the Rules to "Firestone" is referring to Bridgestone Americas Tire Operations, LLC.
- **Full Indianapolis 500® Engine Program** – The guaranteed use of up to two (2) Engines in the Indianapolis 500®, practice, Qualifications and Race.
- **Full-Season** – Scheduled to participate in every Race.
- **Full-Season Entrant Engine Mileage** – The total Engine miles across all installed Engines as allotted for a Full Season Entrant.
- **Good Standing** – INDYCAR decides good standing of an individual and/or entity by a review of:
  - Financial and/or legal status with respect to INDYCAR and Manufacturers, and
  - Such other factors as INDYCAR deems relevant to the decision.
- **Grid** – The physical location where the Cars are positioned in Starting Lineup order prior to the start of a Race.
- **Guaranteed Attempt** – A Car's opportunity to present itself for the Qualifications process.
- **Headings** – The subject headings are included for purposes of convenience only and shall not affect the construction or interpretation of any of the Rules.
- **Homologated** – INDYCAR approved design and location of a component for use at an Event.
- **INDYCAR** – INDYCAR, LLC, the member club of ACCUS; the owner and operator of the NTT IndyCar Series; the owner of the Indy Lights Series; and the sanctioning body for the NTT IndyCar Series, Indy Lights Series, Indy Pro 2000 Championship and USF2000 Championship. INDYCAR includes INDYCAR and INDYCAR's officials, officers, directors, members, owners, successors, assigns, agents, employees, representative and affiliates. "INDYCAR" and "Leaders Circle" are registered trademarks with the United States Patent and Trademark Office and cannot be used without authority from INDYCAR or Brickyard Trademarks, Inc. Any reference in the Rules to "INDYCAR" is referring to INDYCAR, LLC.
- **INDYCAR Group** – INDYCAR, FIA, ACCUS-FIA, Event Promoters, other Members and the officers, directors, employees, agents, affiliates, representatives, owners, successors and assigns of each of them.
- **NTT IndyCar Series** – The IndyCar® Series owned, operated and sanctioned by INDYCAR. INDYCAR includes INDYCAR and INDYCAR's officials, officers, directors, members, owners, successors, assigns, agents, employees, representative and affiliates. NTT IndyCar Series (and design) are registered trademarks of Brickyard Trademarks, Inc., used with permission. Any reference in the Rules to the NTT IndyCar Series may include INDYCAR and any reference to INDYCAR may include a reference to the NTT IndyCar Series, if the context so requires.
- **IRIS** – INDYCAR Information System is the official online communication platform for Competitors.
- **Lapped Car** – A Car that is at least one lap behind all Cars that are on the Race leaders lap.
- **Leaders Circle** – The program whereby INDYCAR provides benefits to Leaders Circle participants in exchange for their participation in all of the Races. Leaders Circle participants must enter into an agreement with INDYCAR, remain in good standing and be uniquely identified by a tax identification number, Car number and Driver. Leaders Circle designations may not be transferred, and/or otherwise assigned without prior written permission by INDYCAR. INDYCAR may limit the number of Leaders Circle participants as it deems appropriate.
- **License** – An authorization approved by INDYCAR and issued by ACCUS-FIA (or another ASN, if applicable) to an individual or entity to participate in a Race as a Driver, Entrant or Official.
- **Manufacturer** – The firm(s), corporation(s) or other business association(s) named on an Associate's membership application approved by INDYCAR, remaining in good standing and uniquely identified by a tax identification number. Manufacturer includes the approved chassis, Tire, Engine and gearbox Manufacturers and their officers, directors, members, owners, successors, assigns, agents, employees, representatives and affiliates.

- **Member** – An individual, firm, corporation or other business association entity named on an annual membership application, approved by INDYCAR and remaining in good standing. Without limitation, each Competitor and Official must be a Member. Member is responsible for Member Group.
- **Member Group** – Member Guest and each third-party Member. The term “Member Guest” shall mean and include any individual whose presence at an Event is at invitation.
- **Non-Qualified Car** – A Car not successfully completing Qualifications. A Non-Qualified Car may be approved by INDYCAR to participate in a limited manner in a Race.
- **Officials** – Any and all authorized INDYCAR officers, employees, agents, representatives and subcontractors. Officials specifically referenced in the Rules include:
  - “Chief Executive Officer”, Mark Miles
  - “President”, Jay Frye
  - “Race Director”, Kyle Novak
  - “Medical Director”, Geoff Billows, MD
  - “Medical Review Officer”, Douglas Aukerman, MD
  - “Race Stewards”, Arie Luyendyk and Max Papis

INDYCAR may replace any Official with another Official(s) at any time. The above-named Officials may delegate their authority in whole or in part to another Official(s) at any time.
- **Open Test** – A Open Test is a period of on-Track activity to: i) promote the Race at the Race Location and ii) to prepare Participants for the Race and for other Races at other venues.
- **Oval/Oval Events** – A Race Location where all on-Track turns are left-handed.
- **Pace Car** – An official Pace Car approved by INDYCAR, driven by an authorized individual and used during on-Track activities.
- **Partial Season Entrant** – An Entrant in one or more, but not all, of the Races during the Racing Season.
- **Participant** – Any individual or entity along with their officers, directors, members, owners, successors, assigns, agents, employees, representatives and affiliates that are in any way associated or connected with Track premises, Testing facilities or other INDYCAR-approved locations or Event including, without limitation, facility owners, Event Promoters, municipalities, racing associations, sanctioning organizations, series organizers, Officials, workers, volunteers, Entrants, Car owners, Drivers, pit crew members, safety crew members, medical/rescue personnel, sponsors, Manufacturers, suppliers, designers, advertisers, inspectors, construction contractors, engineers, architects, insurers and all individuals in a restricted area.
- **Penalty Guidelines** – The penalty issued for a violation of each Sporting Regulation of the Rules during Qualifications and Races and designated other Rules is taken from the Penalty Guidelines. The Penalty Guidelines have been developed by INDYCAR with input from the Race Stewards, Drivers and Entrants, and they shall contain a violation, Rule reference (Rule number and a brief description of the rule), as well as the minimum, mid, and maximum penalty for violation of the Rule.
- **Pit Box** – The area of the Pit Lane specified to an Entrant for service of a Car including refueling, tire changes, and repairs. This area includes both sides of the Pit Wall.
- **Pit Commitment Line** – The time line that decides if a Car is within the Pit Lane boundaries at the time of a Yellow Condition.
- **Pit Entry/Exit Lane** – The lane in Pit Lane closest to the Pit Boxes.
- **Pit Lane** – The part of the Track that leads from the Racing Surface to the Pit Boxes or from the Pit Boxes back to the Racing Surface. It has specified starting and ending points and is defined by painted lines, cones and/or other visible markings.
- **Pit Out Commit Line** – The time line that decides if a Car has followed proper procedures exiting Pit Lane. At some Tracks, the Pit Out Commit Line is the same line as the Blend Line.
- **Pole Position** – The first (1<sup>st</sup>) position in the Starting Lineup.
- **Primary Car** – The first Car presented at technical inspection
- **Provisional Starting Car** – An Entrant who is granted permission to start a Race based on previous championships, current points or other means as determined by INDYCAR or the Indianapolis Motor Speedway, as applicable.
- **Push to Pass** – A system controlled by the ECU that allows for the Engine power to be increased for a period of time when activated by a button press by the Driver.
- **Qualifications** – The process to determine the eligibility and starting position of each Car desiring to participate in a Race by ranking the Car on the basis of its performance in Qualifications.
- **Qualified Car** – A Car that successfully completes Qualifications.
- **Race** – The NTT IndyCar Series race(s) occurring at an Event for which points are awarded.
- **Race Location** – A location where on-Track activities take place.
- **Race Procedure** – Is the manner in which an Event is conducted. It includes, but is not limited to, At Track Procedures described in [Rule 7](#) (On-Track Conditions, Flag Codes and Track condition lights, Timing and Scoring, Pit Boxes, Race Start, Race Restart, Mechanical Conditions, Performance Standards, Pit Procedures, Pit Safety Violations) and Qualifications described in [Rule 8](#).

- **Race Stewards** – The Race Stewards (individually referred to as a Race Steward) are Officials stationed in race control who shall determine on-Track violations of the Sporting Regulations of the Rules during Qualifications and Races. The President of Competition and Operations in his discretion shall select the Race Stewards. Unless otherwise notified, the same individuals shall serve as Race Stewards during every Event. All Race Stewards shall report to the President of Competition and Operations. The President of Competition and Operations will expect and be the sole judge that each Race Steward is unbiased, fair, honest, ethical, and consistent and has comprehensive knowledge of the Sporting Regulations of the Rules and racing as established by these Rules and the interpretations and determinations of the President of Competition and Operations. The President of Competition and Operations may remove any Race Steward at any time if he deems such Race Steward is unsuitable or has a conflict. The Race Stewards shall: i) attend the pre-Race Drivers' meetings scheduled by INDYCAR to provide updates to Competitors on the Sporting Regulations of the Rules generally applicable to NTT IndyCar Series Qualifications and Races and any Sporting Regulations of the Rules specifically applicable to Qualifications and Race; and ii) be available for one (1) hour post-Race and post-Qualifications at the INDYCAR Administration Trailer to review Race and/or Qualifications decisions with Competitors.
- **Racing Season** – All Open Tests and Race Events beginning with the first Race or first Open Test, whichever occurs earlier, and continuing through the final Race.
- **Racing Surface** – The area designated by INDYCAR as eligible for use during competition. It may be formed by boundaries such as a wall or a line. It does not include grass or runoff areas.
- **Registration** – The unique identity number assigned to a specific Car by Dallara.
- **Restarting Lineup** – The order of Cars on-Track for the restart of a Race.
- **Road Course Event** – A purpose-built permanent Track where turns are left and right-handed.
- **Rookie Driver** – A Driver is a Rookie Driver in the NTT IndyCar Series if the Driver has i) not participated in more than four (4) NTT IndyCar Series Races in a Racing Season or ii) participated in less than eight (8) NTT IndyCar Series Races in his/her career.
- **Rookie Driver - Indianapolis 500<sup>®</sup>** – A Driver is a Rookie Driver in the Indianapolis 500<sup>®</sup> Mile Race if the Driver has not participated a previous Indianapolis 500<sup>®</sup> Mile Race.
- **ROP** – Rookie Orientation Program. A three (3) phase Test, supervised by INDYCAR to demonstrate Car control, placement and a consistent driving pattern by a Rookie Driver.
- **Rules** – This NTT IndyCar Series Rule Book, including without limitation, Aero Kit Regulations, Engine Regulations, supplementary guidelines, Substance Abuse Policy, Social Media Policy, Style Guide, Penalty Guidelines and bulletins issued by Officials, whether containing Rules applicable only to a particular Event(s) or containing Rules of general applicability. The most current version is available at <http://epaddock.indycar.com/rulebook>. Notwithstanding the foregoing, Rules may be issued verbally in mandatory meetings such as Drivers meetings held during Events.
- **Season Start** – A designated date or the first Open Test or the first on-Track day of the first Race of a given calendar year, whichever comes first.
- **Short Indianapolis 500<sup>®</sup> Engine Program** – The guaranteed use of one Engine in Indianapolis 500<sup>®</sup>, practice, Qualifications and Race.
- **Short Oval Events** – An Oval/Oval Event with a Track distance of 1.3 miles or less.
- **Single Race Event Entrant** – An Entrant whose participation is scheduled for only one Event at a time, even if participating in consecutive Events.
- **Speedway/Superspeedway Events** – An Oval/Oval Event with a Track distance greater than 1.3 miles.
- **Sporting Regulations** – Sporting Regulations are the Race Procedures of the Rules including, but are not limited to, on-Track competition such as blocking, contact, restart violations, Pit Lane infractions, Qualifications interference, local yellow performance reduction expectation, Track boundary infraction, packing up under Yellow Condition or failing to pace; however, it does not include technical, operations or off Track competition such as Engine Regulations, Aero Kit Regulations, and Substance Abuse Policy violations. The Race Stewards shall determine violations of the Sporting Regulations of the Rules during Qualifications and Races.
- **Start/Finish Line** – The areas of a Track specified by INDYCAR to decide the start, lap completion, and/or completion of an on-Track activity. If applicable, it may extend across and include Pit Lane.
- **Starting Lineup** – The order of Cars on-Track for the start of a Race.
- **Steward** – An individual designated by the President of Competition and Operations to have specific authority to assist with the application, construction, interpretation and enforcement of the Rules.
- **Steward's Review** – The request from a Race Steward and/or the Race Director during Qualifications and/or a Race for review of an incident as a potential violation of the Sporting Regulations of the Rules for issuance of a penalty.
- **Street Course Event** – A purpose-built temporary Track where turns are left and right-handed.
- **Team** – One or more Entrants under common ownership and/or control as determined by INDYCAR.
- **Test** – Any period during which a Member conducts any Testing.
- **Testing** – The use of the approved chassis, Engine, Aero Kit, gearbox and Tires, separately or in any combination during a period other than practice, Qualifications or a Race.
- **Tire(s)** – Tires supplied by Firestone, approved by INDYCAR, and governed by these Rules.
- **Title Sponsor** – NTT (Nippon Telegraph & Telephone Corporation), its affiliates and the successors, assigns, officer, directors, owners, members and representatives and employees of each of them.

- **Track** – The area including without limitation the Racing Surface, pit entrance lanes, Pit Lane and pit exit lanes located between the outer and innermost retaining walls.
- **Track Condition** – The status under which on-Track activity is conducted.
- **Unapproved Engine Change-Out** – An Engine change not approved by INDYCAR and subject to a penalty.
- **Use** – This is defined as being propelled under power generated by the Engine.
- **Xtrac** – Xtrac, Inc, the approved gearbox manufacturer. Any reference in the Rules to “Xtrac” is referring to Xtrac, Inc.